

## Profile

- Various sizes
- Plastic-coated or bright-finished surface
- Various hub versions



HST8  
HST11

HST7

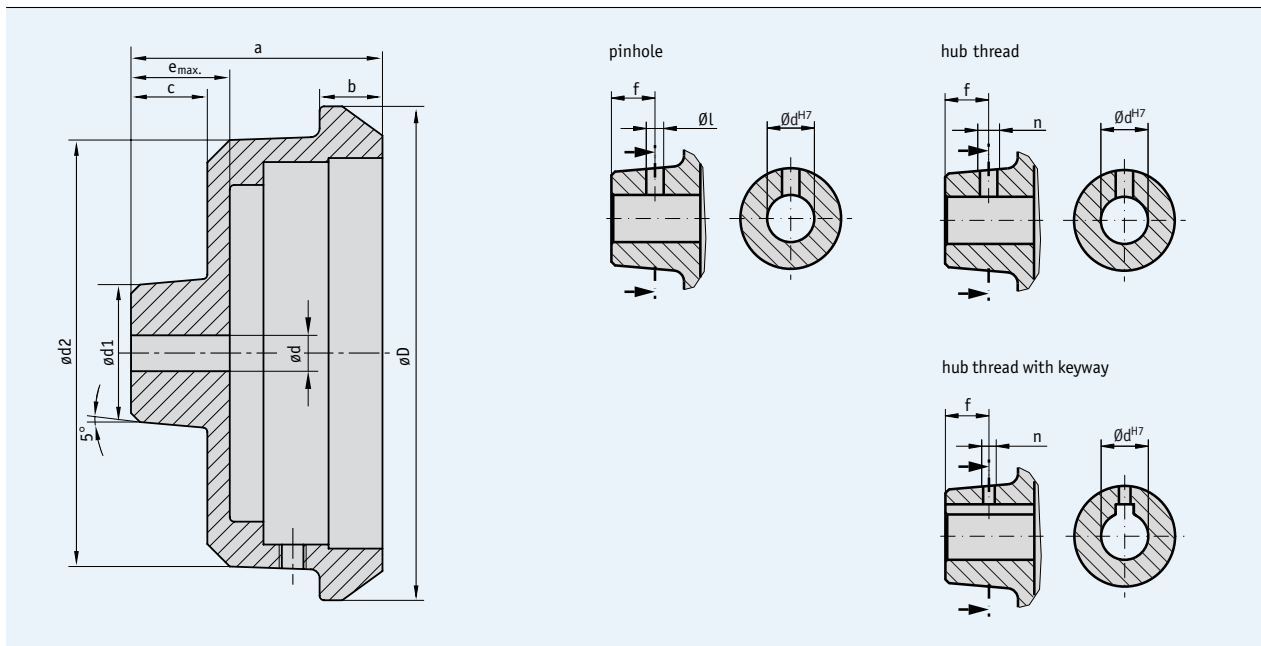

## Mechanical data

### ■ Dimensions

type	ØD	Ødv	Ødx	Ød1	Ød2	a	b	c	e	suitable for	Weight	material
HST 7	78	5.8	20	32	60	50	20	15	20	S50/1	0.2 kg	aluminum
HST 8	75	5.8	12	20	60	43	10	10	13	S50/1	0.2 kg	aluminum
HST 11	110	6.8	16	30	95	56	14	17	22	S80/1; SZ80/1	0.5 kg	aluminum

dv = d predrilled; dx = d max.

### ■ Special versions

Handwheel type	HST 7					HST 11					
	6 ... 8	9, 10	11, 12	13 ... 16	17 ... 20	7, 8	9, 10	11, 12	13 ... 15	16	
Bore dH7											
Groove width for keyway JS9		3	4	5			3	4	5	5	
Pinhole	3.8/10	3.8/10	3.8/10	4.8/10	4.8/10	3.8/12	3.8/12	3.8/12	4.8/12	4.8/12	
Hub thread	without keyway JS9	M4/10	M4/10	M4/10	M6/10	M6/10	M4/12	M4/12	M4/12	M6/12	M6/12
	with keyway JS9		M3/10	M3/10	M4/10			M3/12	M3/12	M4/12	

Additional special versions available on request.

Handwheel type	HST 8		
Bore dH7	6 ... 8	9, 10	11, 12
Groove width for keyway JS9	3		
Pinhole	3.8/6	3.8/6	3.8/6
Hub thread	M4/6	M4/6	M4/6

Note: Characters highlighted in orange are order features.

## Order

### Order table

Feature	Order data	Technical data	Additional information
Handwheel type	HST... A	7, 8, 11	see "Dimensions"
Surface	B	unvarnished	not with HST 7
	CS	plastic-coated, black RAL9005 half-matt others on request	
Bore Ød	d vorg.	predrilled	see "Dimensions", value Ødv
	...	6 ... 20 d max. in mm steps (H7)	see "Dimensions" (smallest bore corresp. with predr.)
Keyway	OP	without keyway	
	JS9	light seat	according to DIN 6885 T1
	P9	tight seat	according to DIN 6885 T1
Pinhole (only without keyway)	OS	without pinhole	see table "Special versions", depending on handwheel type, only if hub thread "ONG"
	...	diameter "Øl"/measure "f" (e.g., 3.8/12)	
		others on request	
Hub thread	ONG	without hub thread	see table "Special versions", depending on handwheel type, only if pinhole "OS"
	...	thread "n"/measure "f" (e.g., M4/12)	
		others on request	
Hub turned down	OAN	without turned-down hub	
		others on request	
Position indicator mounted (*)	PM	position indicator mounted	
	PS	separate position indicator	

\* separate order of a position indicator required (see pages 74-82)

### Order code

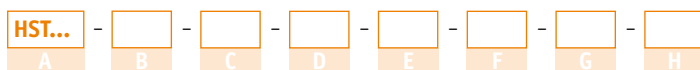

Scope of delivery: HST...

Accessories:  
End plate

Page 103

Additional information:  
General information and areas of application

Page 68 cont.