

Key Features

- Easy Installation and calibration
- Rugged system is dirt, dust, and grease proof
- UL and CSA approved to applicable standards
- Explosion-proof (XP) cast aluminum housing
- Shaft reversal de-energizes relay
- Unit automatically resets when reverse motion stops



Description

The UDS1000 is a complete system designed to detect shaft rotation reversal. During operation, the UDS1000 energizes its relay when the monitor shaft is either at rest or rotating in the desired direction. When the monitored shaft rotates in reverse, or the “wrong direction”, the relay de-energizes. The relay contacts can be used for equipment shutdown, to prevent start-up, or to provide an alarm. The UDS1000 is ideal for detecting reverse rotation on Pump Shafts, Motors, Conveyors, Fans/Blowers, and more. The standard UDS1000 system includes the UDS1000 speed switch, a 906B Sensing Head, and a 255 Pulser Disc. Electro-Sensors’ speed switches bring efficiency and safety to your operations by preventing machine damage, product waste, and costly downtime.



Standard System with: UDS1000 Rotation Reversal Switch, 906B Speed Sensor, 255 Pulser Disc

Principle of Operation

The UDS1000 works with a shaft-end mounted Pulser Disc (or optional split-collar Pulser Wrap) which generates an alternating magnetic field that is picked up by the large gap non-contact sensor. The sensor transmits this speed signal as a quadrature digital pulse (frequency) to the switch via a 4-conductor shielded cable. The UDS1000 decodes this frequency signal to determine shaft direction. The relay output can then be used for equipment shutdown, to prevent start-up, or to provide an alarm, assuring machine protection and process integrity. The UDS1000 is fail-safe; any loss of power during operation will de-energize the relay.

Dimensions

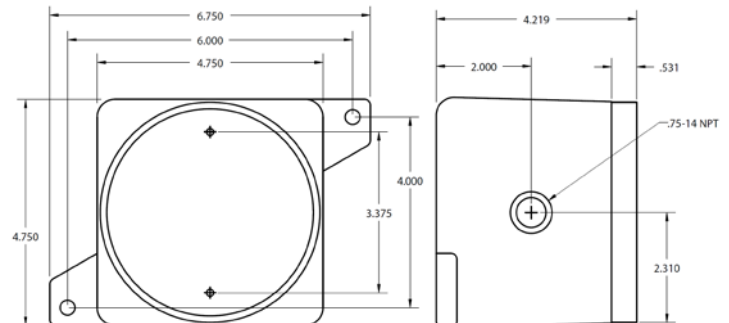

UDS1000 Specifications

Input Power	
Voltage	115 VAC, 60 Hz std 230 VAC, 60 Hz (opt) 12 Vdc (opt) 24 Vdc (opt)
Input Signal	
Sensor Supply	12 VDC @ 50 mA Max.
Type	Quadrature, NPN open Collector
Amplitude	12 Vdc
Pull-Up	2.2K Ohms
Frequency Range	0-666.67 Hz
Set Point Relay	DPDT isolated, 5 Amp, 115 Vac resistive
General Specifications	
Housing/cover	Cast aluminum, CSA approved, UL Rated: Class I - Group C, D; Class II - Group E, F, G; Class III; NEMA 4X
Actuation State	Over-Speed in Reverse Rotation
Relay Contact Rating	5 Amp @ 30 Vdc, or 240 Vac resistive
Adjustment	Potentiometer for Over-speed Set-point; 4 Speed Ranges
Setpoint Hysteresis	6.6%*
Relay Contact Rating	5 Amp @ 30 VDC, or 250 VAC Resistive
Physical Environment/parameters	
Storage Temperature	-40°C to +65°C*
Operating Temperature	-40°C to +65°C*
Storage Temperature	-65 °C → +125 °C (-85°F → +257 °F)
Enclosure Rating	Cast Aluminum, NEMA 4X
Shipping Weight	7 lbs
 <p>Class I, Div 1, Group C, D Class II, Div 1, Group E, F, G UL File: E249019</p>	

Ordering

Model Description	Part Number
UDS1000 115 VAC - Standard	800-050113
UDS1000 230 VAC	800-050114
UDS1000, 12 VDC	800-050115
UDS1000, 24 VDC	800-050116

UDS1000 Standard System

- Shaft Speed Sensor
- Shaft Rotation Reversal Switch (UDS1000)
- Shaft Speed Pulse Generator

These are the most popular system components.
Many other options are available.

System Options	Part Number
906B Hall Effect Speed Sensor	775-000504
907B XP Hall Effect Speed Sensor (Explosion-Proof)	775-006100
Standard 255 Nylon Pulser Disc, 4" Diameter, 16 Magnets	700-000200
Split Collar Pulser Wrap (PVC, Aluminum, Stainless Steel)	Custom (See Website)

Customization

If one of our standard products does not meet your specifications, please call one of our applications specialists. Many of our products can be customized to fit specific needs.

Additional Information

See UDS1000 Installation and Operating Manual for complete details, specifications, and programming instructions.