



HazardPRO™
Wireless Hazard Monitoring

HazardPRO

Temperature and Shaft RPM Sensors

USERS MANUAL

(with I.S. control drawing)

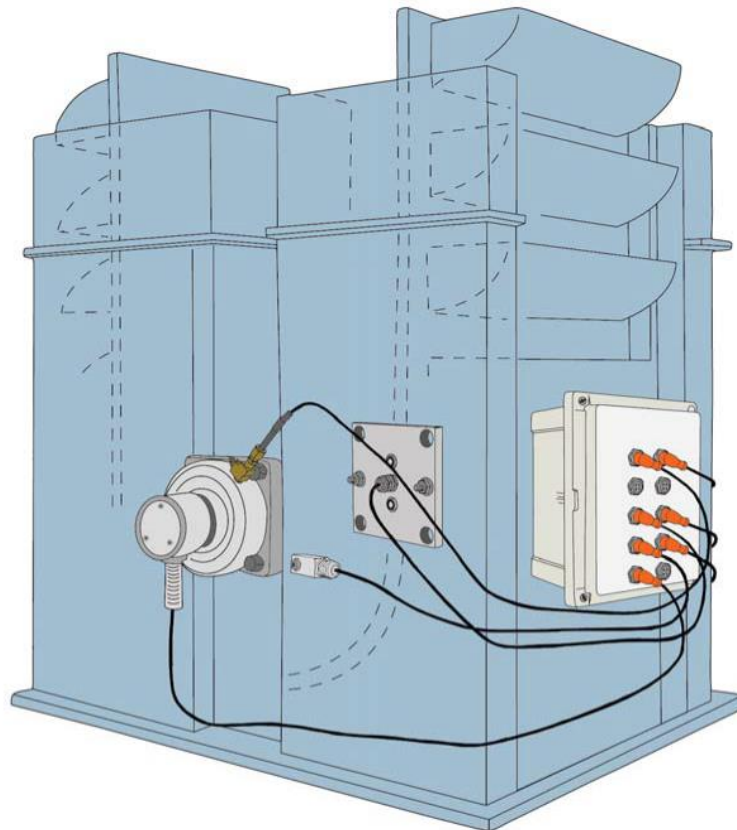

Description

HazardPRO temperature sensors read the temperature of bearings, rub blocks, and equipment surfaces and are 2-wire, loop-powered devices. All models are compatible with HazardPRO nodes, standard I.S. barriers, and PLC analog inputs and are identical with the exception of the measurement probe. HazardPRO temperature sensors are optimized for bearing temperature measurement (probe), belt alignment temperature measurement (brass rub-block), and measuring the ambient surface temperature on a machine.

HazardPRO shaft RPM sensors measure the speed of the tail shaft of the equipment being monitored. The sensor sends a pulse output to the HazardPRO node which calculates the speed of the shaft.

All models come ready to use and require no user calibration.

The HPZ bearing temperature sensor mounts into 1/8" or 1/4" NPT grease-fitting (zerk) taps.

The HPA ambient temperature sensor mounts onto a flat surface with a #12 screw.

The HPS stud-mount temperature sensor is mounted into a 3/8"-16 tapped hole. The HPB belt alignment sensor is an assembly for measuring the temperature of a brass belt alignment block.

The HPR shaft RPM sensor mounts into an EZ 1 Mag bracket assembly which installs on the mounted shaft via a 1/2"-13 UNC-tapped hole that is drilled in the center of the shaft.

Installation

HazardPRO Bearing Temperature Sensor (HPZ)

HPZ has a brass fitting that replaces the existing bearing grease zerk and allows proper placement of the bearing temperature sensor. Unscrew the existing zerk from the bearing and replace it with the HazardPRO zerk fitting. Assemble the sensor probe into the fitting as shown using the brass compression ring or the rubber o-ring. Before tightening the hex cap, push the probe all the way in until it touches the bearing race and then back it out 0.1 inch. This allows grease to flow freely around the probe. Tighten the hex cap nut enough to seal the brass compression ring and hold the probe in position – do not over-tighten.

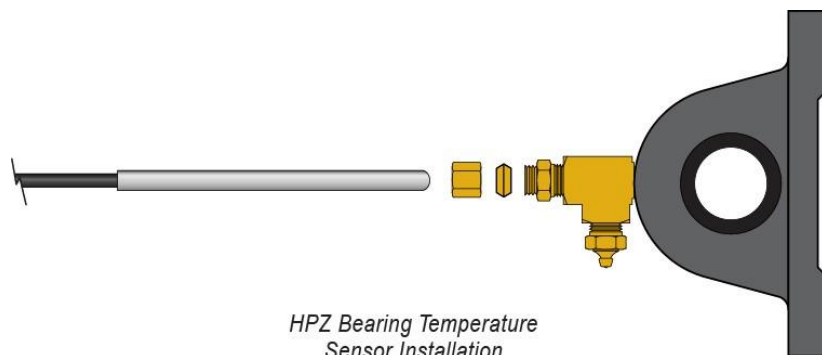

HazardPRO Stud-Mount Temperature Sensor (HPS)

The HPS screws into a 3/8"-16 tapped hole. Use a lock washer or Loc-Tite™ to prevent loosening after installation. With the cable unconnected (to prevent twisting) screw the brass probe all the way into the threaded hole. An optional magnet-mount brass block with a 3/8"-16 tapped hole in the center is available to be used if tapping on the equipment is not preferred.



HPS Stud-Mount Temperature Sensor Installation

HazardPRO Ambient Sensor (HPA)

The HPA mounts onto a flat surface with a #12 self-tapping screw or a #10 bolt, lock washer, and nut can be used instead. When used as the ambient compensation sensor in a HazardPRO system, mount the HPA sensor on the machine such that it gets equal sunlight exposure as the bearing and belt alignment sensors do on that side of the machine.

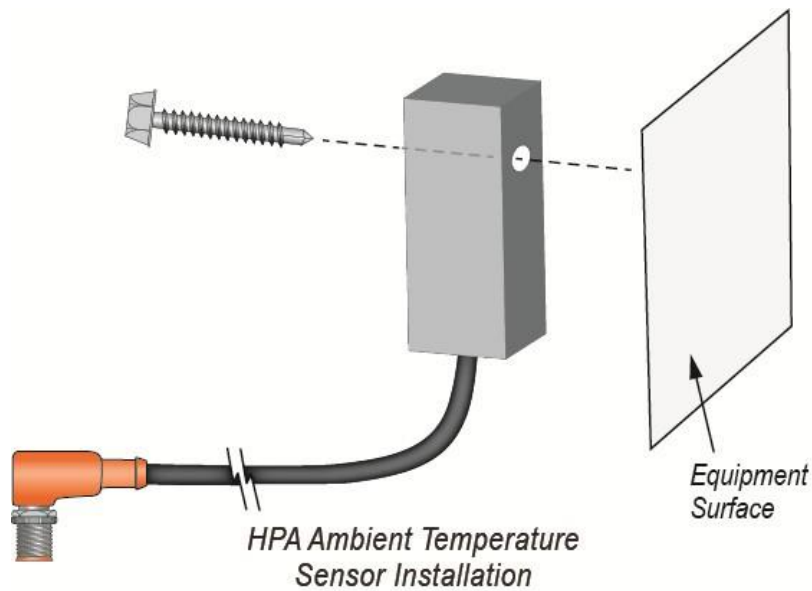

HPA Ambient Temperature Sensor Installation

HazardPRO Belt Alignment Temperature Sensor (HPB)

The HPB is mounted in a 2.25" hole centered on the belt of the equipment being monitored. The HPB is held in place with two 1/4"-20 bolts, lock washers, and nuts. Measure the distance from the center of the shaft to the center of the belt. On tail sections, determine the location of the pulley when the tension adjustment is at its highest point. Mark this location for a vertical reference.

Use a template to mark hole locations and drill one 2.25" hole for the belt alignment block and two 1/4" holes for the mounting bolts so that the center of the belt alignment brass block is over the center of the belt using the measurement distance from the center of the shaft to the center of the belt. On head sections where there is no tension adjustment, measure the distance from the center of the shaft to the center of the belt. Drill one 2.25" hole and two 1/4" holes so that the center of the belt alignment brass block is over the center of the belt using this measurement distance.

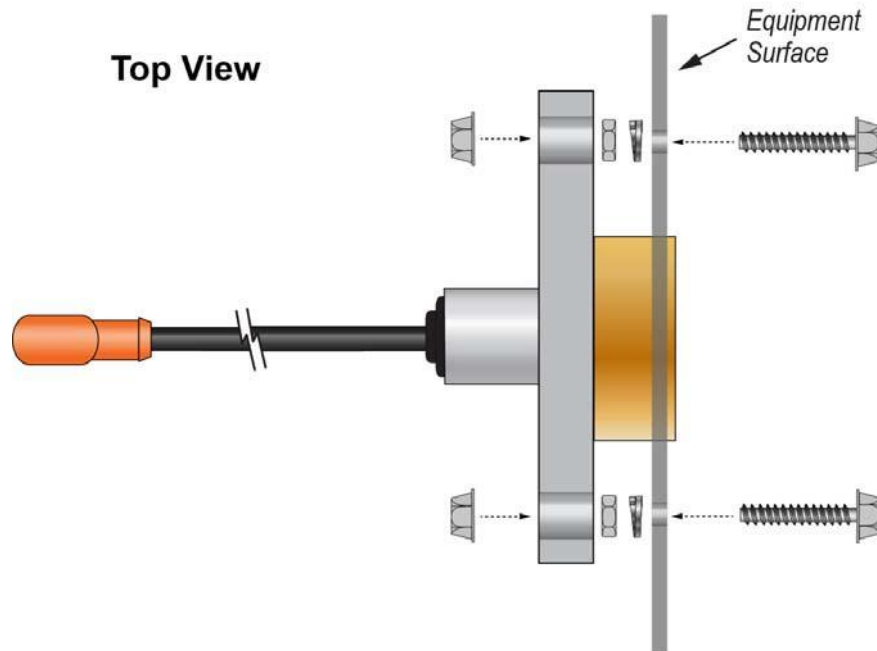

HPB Belt Alignment Temperature Sensor Installation

HazardPRO Shaft RPM Sensor (HPR)

The HPR is mounted in an EZ 1 Mag bracket. The bracket has a 1/2"-13 UNC mounting thread. Many shafts are already center-drilled and tapped for this thread. If not, the shaft must be center-drilled and tapped for 1/2"-13 UNC to a depth of 1". Attach the EZ 1 Mag bracket following the instructions. An optional MM-1.25" mounting magnet can be used if the shaft is not tapped. The surface of the shaft must be free of rust and lightly coated with silicone grease to prevent rust and allow the magnet to be moved into the center position.

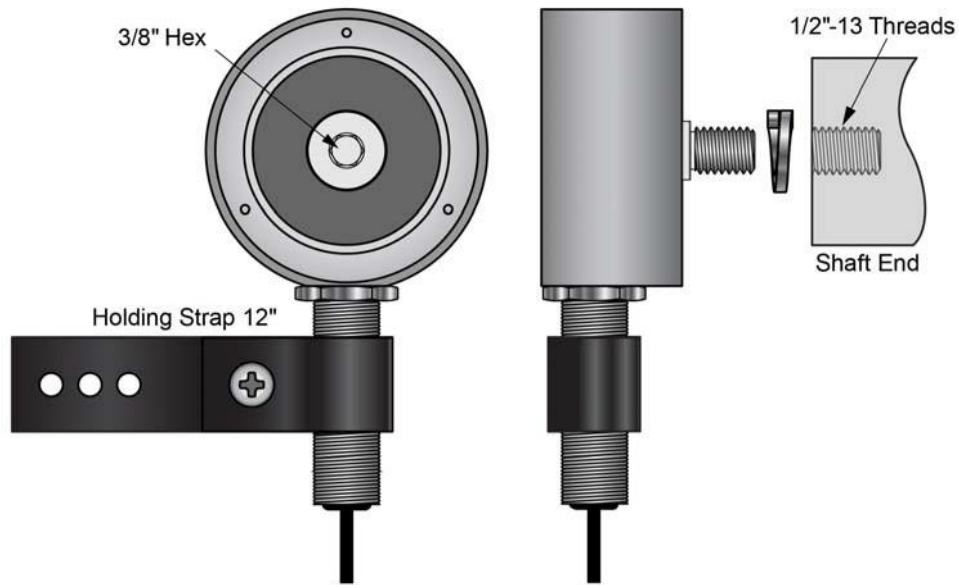

HPR Shaft RPM Sensor and EZ 1 Mag Mount Installation

Wiring Diagram (non I.S.)

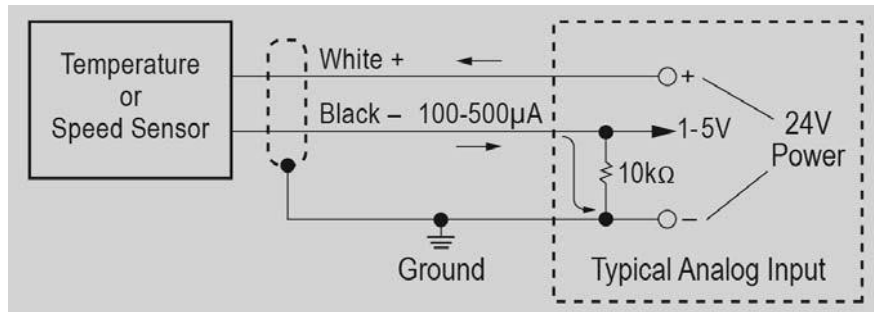

I.S. Control Drawing (990-006700)

Entity Parameters	Vmax	21 Vdc
	I _{max}	21 mA
	P _{max}	0.11 W
	C _i	0 uF
	L _i	0 uH

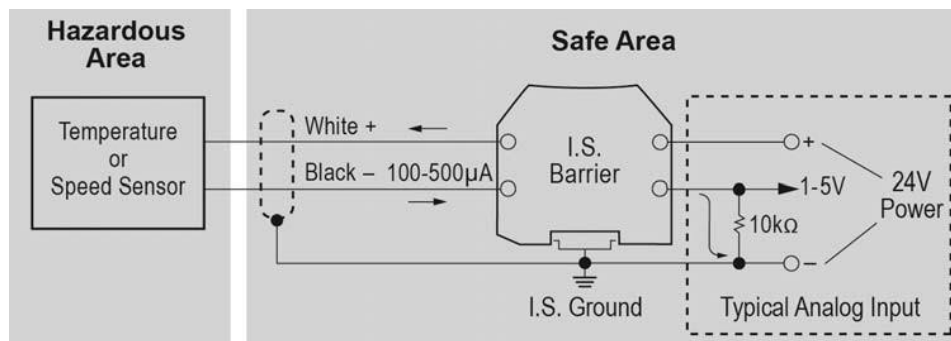

I.S. Requirements	Equip	Barrier	Notes
	$V_{max} \geq$	V_{oc}	V_{oc} is the barrier max open-circuit voltage
	$I_{max} \geq$	I_{sc}	I_{sc} is the barrier max short-circuit current
	$P_{max} \geq$	P_o	If P_o is not known, use $P_o = (V_{oc} * I_{sc})/4$
	$C_i + C_c \leq$	C_a	$C_c = (\text{cable pF/ft}) * \text{length (in ft)}$, C_a is the barrier max allowed external capacitance
	$L_i + L_c \leq$	L_a	$L_c = (\text{cable } \mu\text{H/ft}) * \text{length (in ft)}$, L_a is the barrier max allowed external inductance

Selected barriers must be third party approved as providing intrinsically safe circuits for the application. The transmitter-barrier cable length is limited by the C_c , L_c restrictions given above. If the cable pF/ft and/or $\mu\text{H/ft}$ values are unknown, use 60 pF/ft and/or 0.2 $\mu\text{H/ft}$.

The DIN rail (I.S. Ground) must be insulated from the surrounding cabinet (and all other potentials) and connected to earth ground at the 24V supply only. See NEC Article 504, CEC Section 18.

Barrier output current must be limited by a resistor such that the output voltage-current plot is a straight line drawn between open-circuit voltage and short-circuit current. Barriers must be installed in accordance with barrier manufacturer's control drawing and Article 504 of the National Electrical Code, ANSI/NFPA 70, for installation in the United States, or Section 18 of the Canadian Electrical Code for installations in Canada.

When required by the manufacturer's control drawing, the barrier must be connected to a suitable ground electrode per the National Electrical Code, ANSI/NFPA 70 or the Canadian Electrical Code, as applicable. The resistance of the ground path must be less than 1 ohm.

Control equipment must not use or generate more than 250 V rms or dc with respect to earth.

Warning: Substitution of components may impair intrinsic safety.

Warning: To prevent ignition of flammable or combustible atmospheres, read, understand and adhere to the manufacturer's procedures.

Sensor Output	Celsius	$I = 273.2\mu A + (T^{\circ} * (1\mu A/^{\circ}C))$ $T(^{\circ}C) = (I - 273.2\mu A)$
	Fahrenheit	$I = 255.4 \mu A + (T^{\circ} * ((1\mu A/^{\circ}F)/1.8))$ $T(^{\circ}F) = (I - 255.4) * 1.8$
Specifications	Vin (min → max)	5 → 21 Vdc
	Operating Temp	-40 → 120 °C (measurement probe) -25 → 75 °C (ambient)
	Accuracy	±1 °C (at 25 °C) ±3 °C (at -40 °C, 120 °C)
Cable	Connection	M12, 4-pin keyed
	Length	2 m (6 ft) and 5 m (16 ft) standard cable lengths (Other lengths are custom ordered)
Protection	Class II, Div 1, Groups E, F, G, Class III, Div 1 Zone 20, AEx ia IIC T100 °C Da T5 -25 °C ≤ Ta ≤ 75 °C Type 4, IP65 Install per user's manual (990-006600) and control drawing (990-006700)	



Dimensions

HPZ Bearing Temperature Sensor

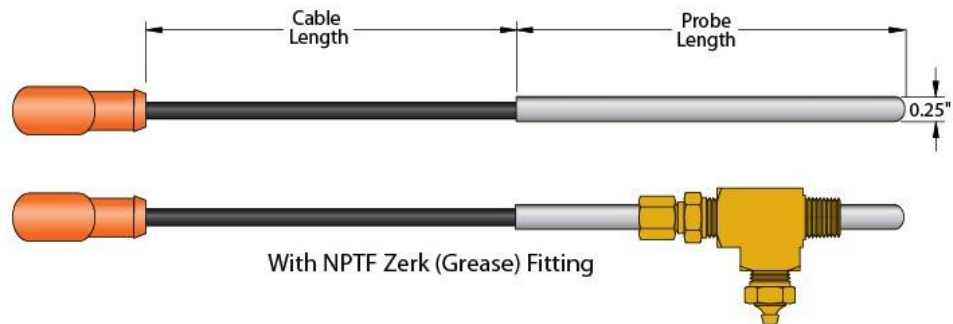

HPA Ambient Temperature Sensor

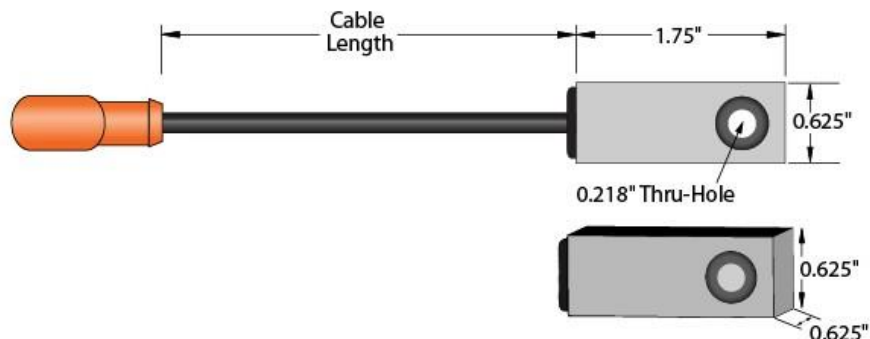

HPS Stud-Mount Temperature Sensor

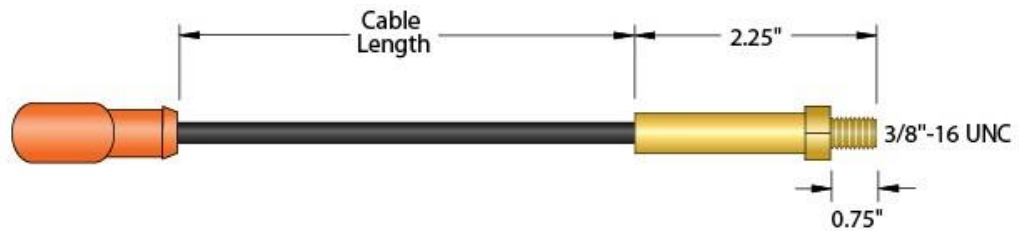

HPB Belt Alignment Sensor

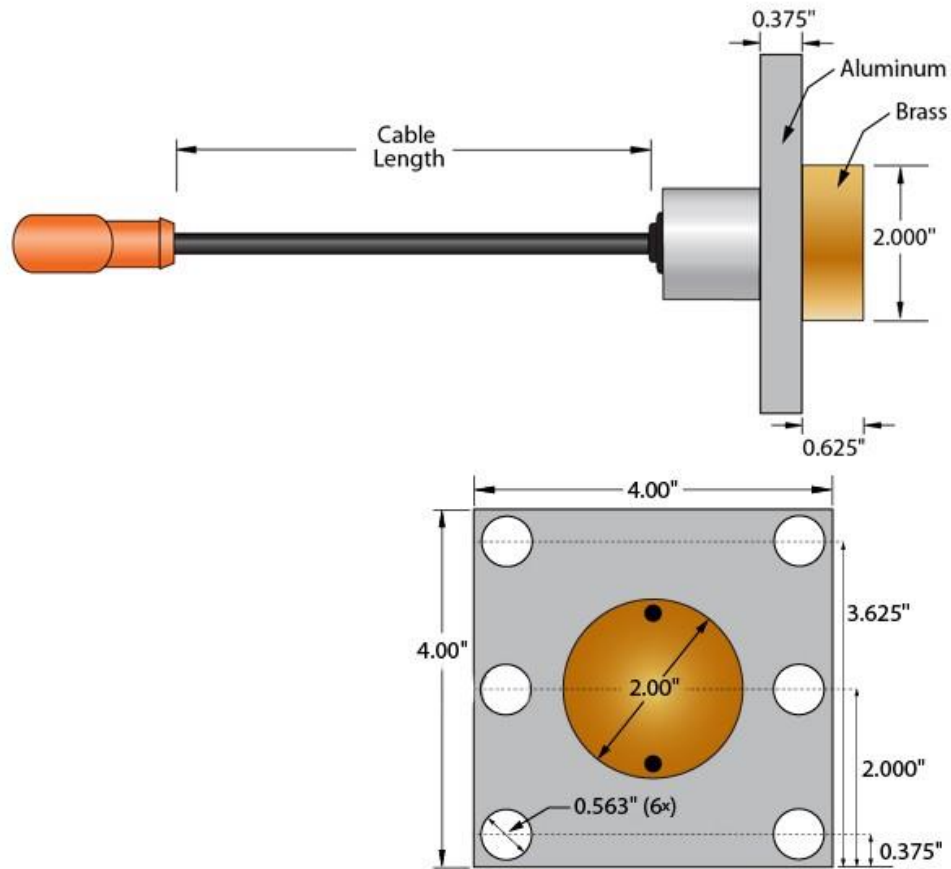

HPR Shaft RPM Sensor

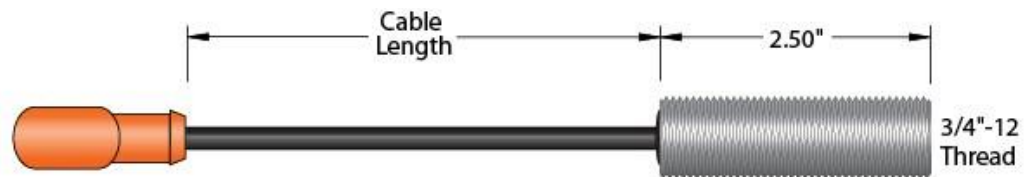

Models

Bearing Temperature Sensor

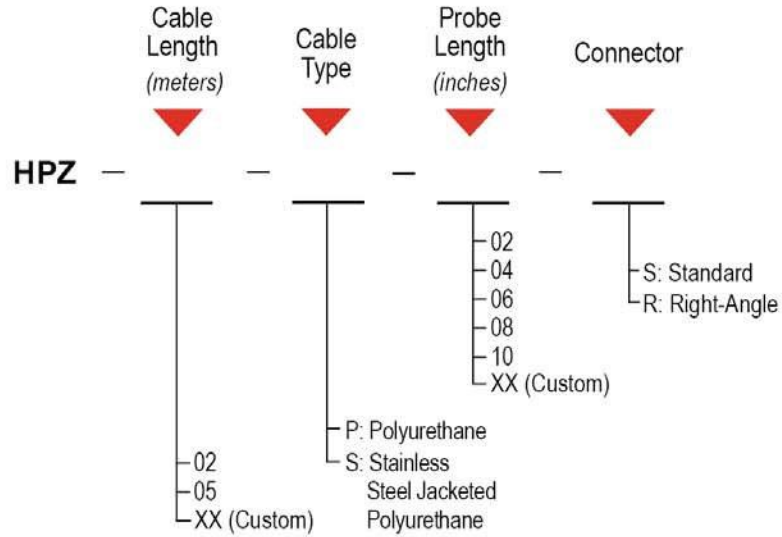

Ambient Temperature Sensor

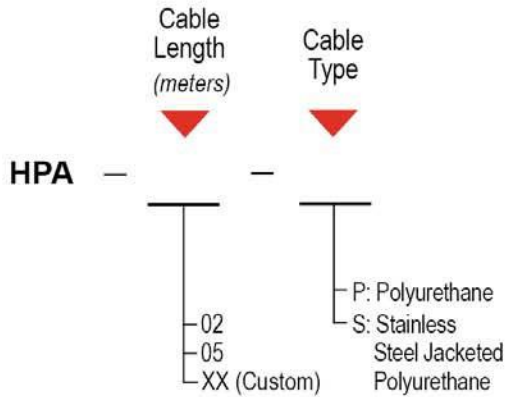

Stud-Mount Temperature Sensor

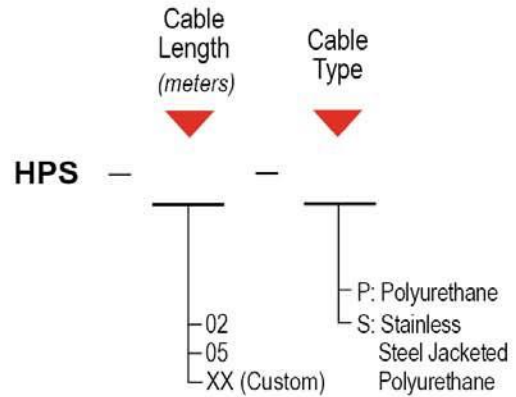

Belt Alignment Sensor

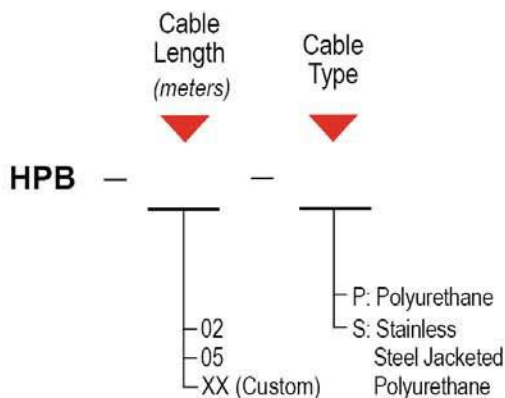

Shaft RPM Sensor

