



RTDZ, RTDZ-LT (1/2 in)

RTDS, RTDS-LT (1/2 in)

RTD Temperature Sensors

USERS MANUAL

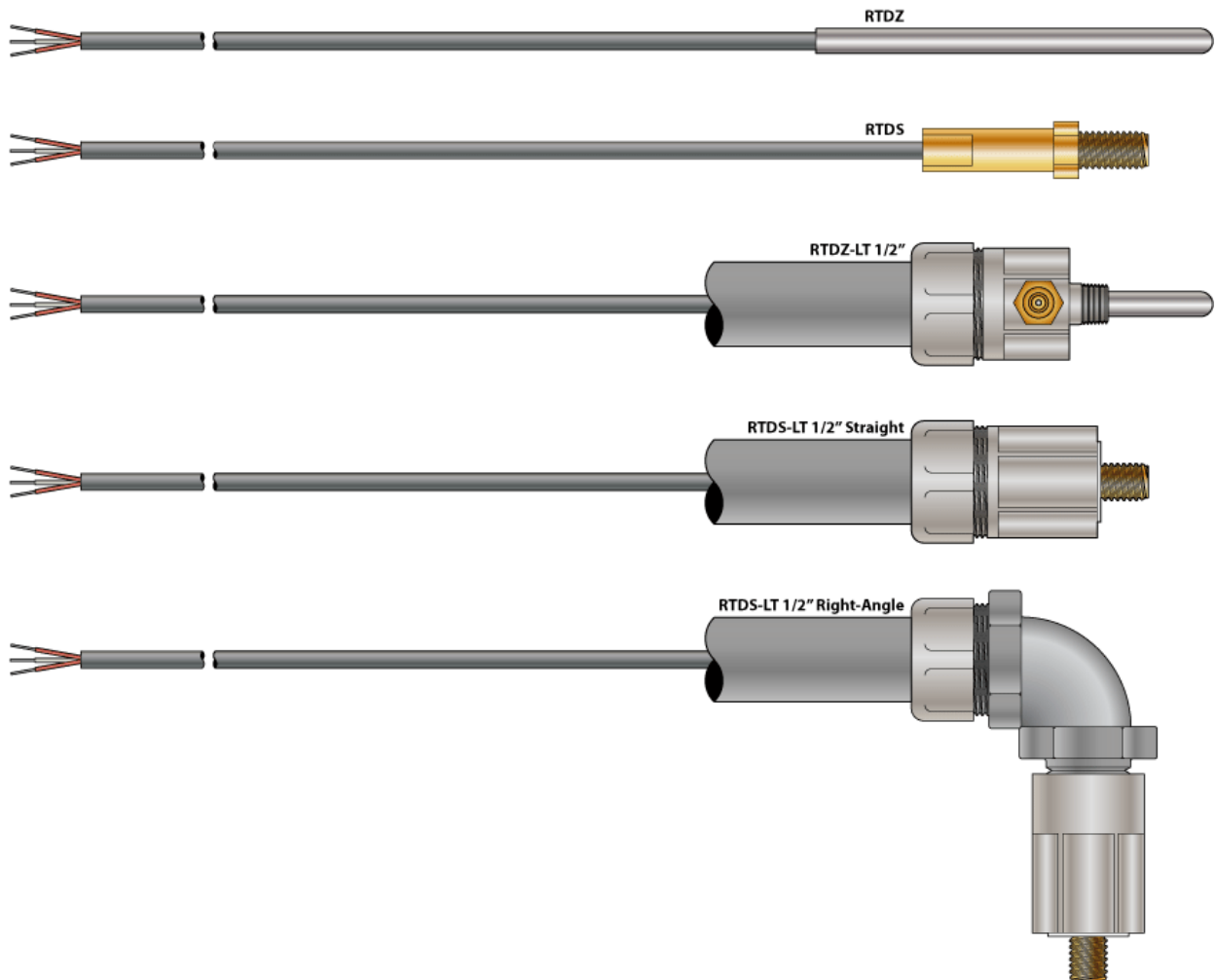

6111 Blue Circle Drive
Minnetonka, MN 55343
Phone: 952-930-0100
Fax: 952-930-0130
ISO 9001:2008 Certified



Free Catalog and Application Assistance
1-800-328-6170
Visit us online
www.electro-sensors.com
990-004005 Rev B

Description

RTDZ, RTDZ-LT, RTDS and RTDS-LT are resistance-output Pt100 RTD temperature sensors with 3-wire cable (specify length).

RTDZ models have ¼ in diameter stainless steel probes (specify length).

RTDZ-LT (½ in) models are RTDZ models with a detachable ½ in flexible liquid-tight Z-LT conduit fitting.

RTDS models have a 3/8-16 brass stud probe.

RTDS-LT (½ in) models are an RTDS with a fixed (non-detachable) ½ in flexible liquid-tight conduit fitting (specify straight or right-angle).

The measurement probe and fitting options are optimized for many industrial applications including Class II grain handling facility shaft bearing (RTDZ-LT) and belt rub-block (RTDS-LT) temperature measurement.

Installation

RTDZ-LT (½ in)

Shaft bearing installation:

Unscrew the existing grease nipple from the bearing housing and replace it with the Z-LT (½ in) fitting body as shown. Tighten enough to seal – do not over-tighten.

Assemble the RTDZ probe into the fitting as shown using the brass compression ring or rubber o-ring and other hardware. Before tightening the hex cap, push the RTDZ probe all the way in until it bottoms out, then back it out slightly (approx. 1/16 in from the bottom). Tighten the hex cap enough to seal and firmly position/hold the probe - do not over-tighten. Slide the gland (with ground terminal) and ring over the end of the conduit and screw the cone into (and over) the end of the conduit. Install the conduit over the cable and secure it to the Z-LT (½ in) fitting body by tightening the gland. Tighten enough to seal – do not over-tighten. Properly earth the ground terminal per the applicable electrical codes.

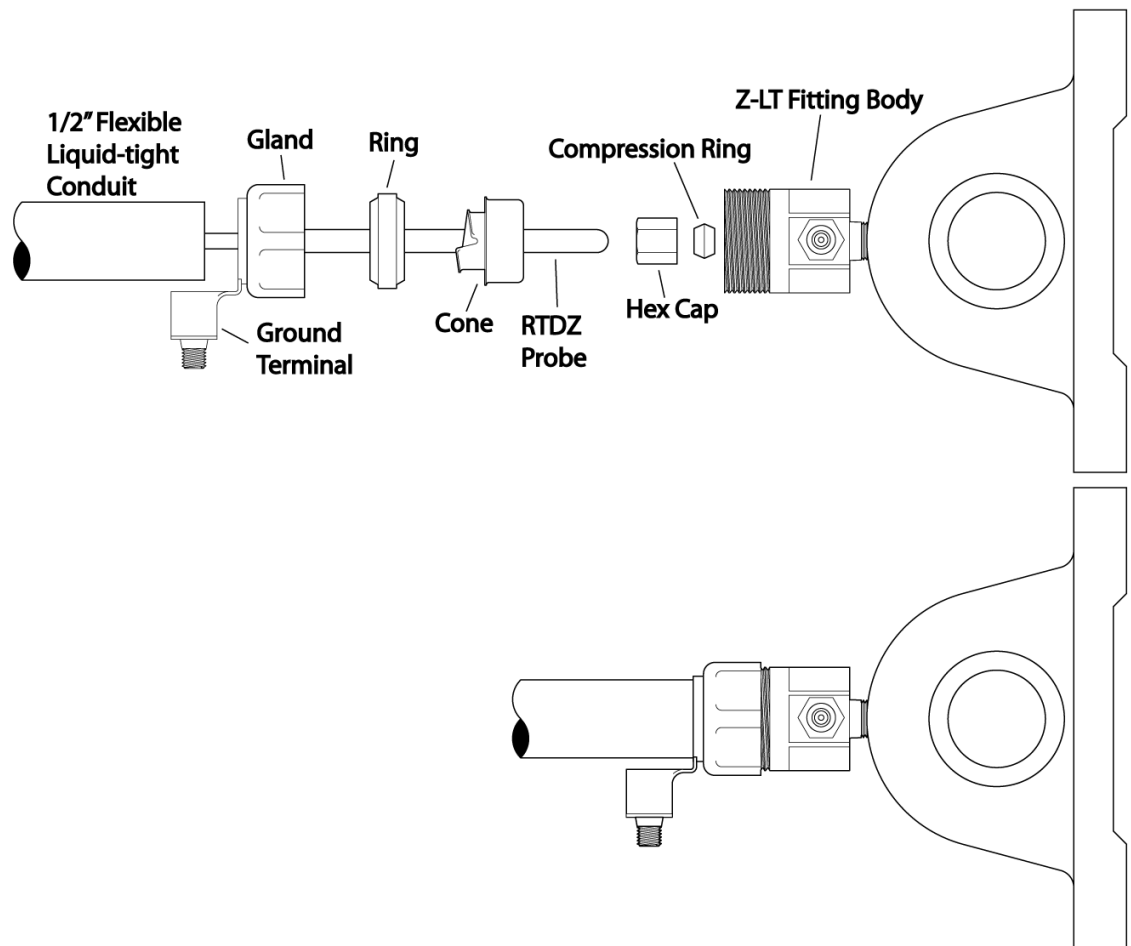

RTDZ-LT (½ in) installation

Installation (cont.) RTDS-LT (1/2 in, right-angle and straight)

Grain conveyor rub-block installation:

With the teflon washer installed over the brass threaded post, screw the RTDS-LT (1/2 in) into a 3/8-16 threaded tap (e.g. in a brass rub-block) as shown. Do not over-tighten. Slide the gland (with ground terminal) and ring over the end of the conduit and screw the cone into (and over) the end of the conduit. Install the conduit over the cable and secure it to the RTDS-LT (1/2 in) fitting by tightening the gland. Tighten enough to seal – do not over-tighten. Properly earth the ground terminal per the applicable electrical codes.

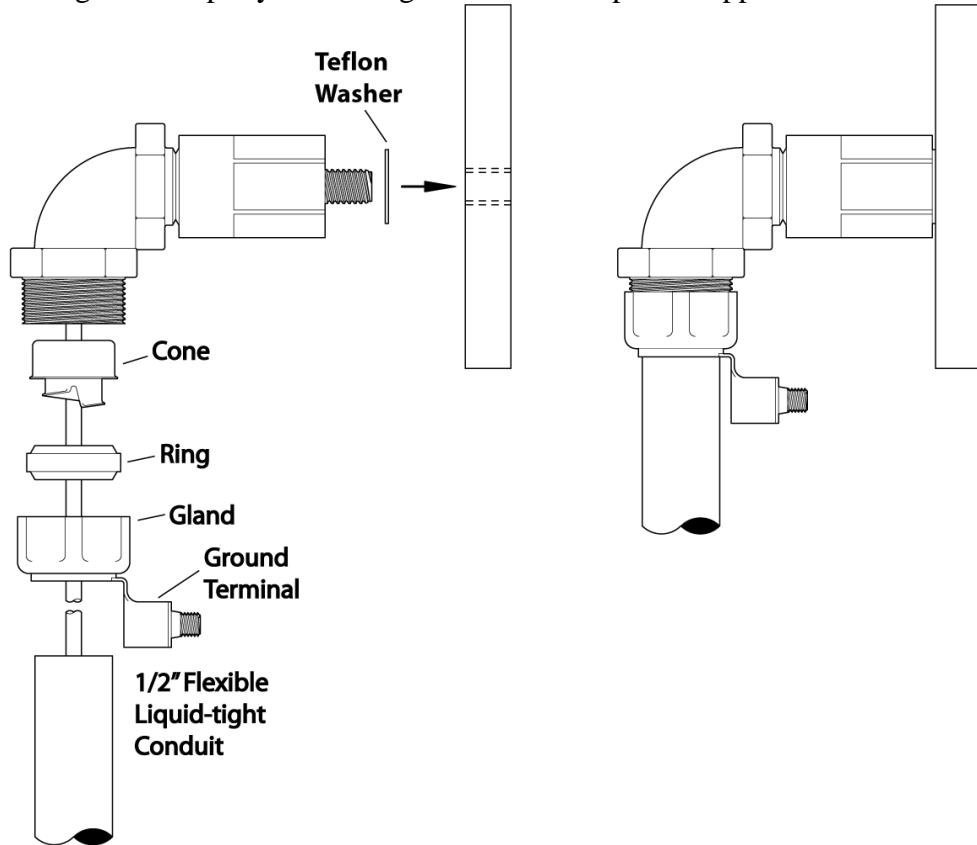

RTDS-LT installation (1/2 in right-angle shown)

Dimensions (in)

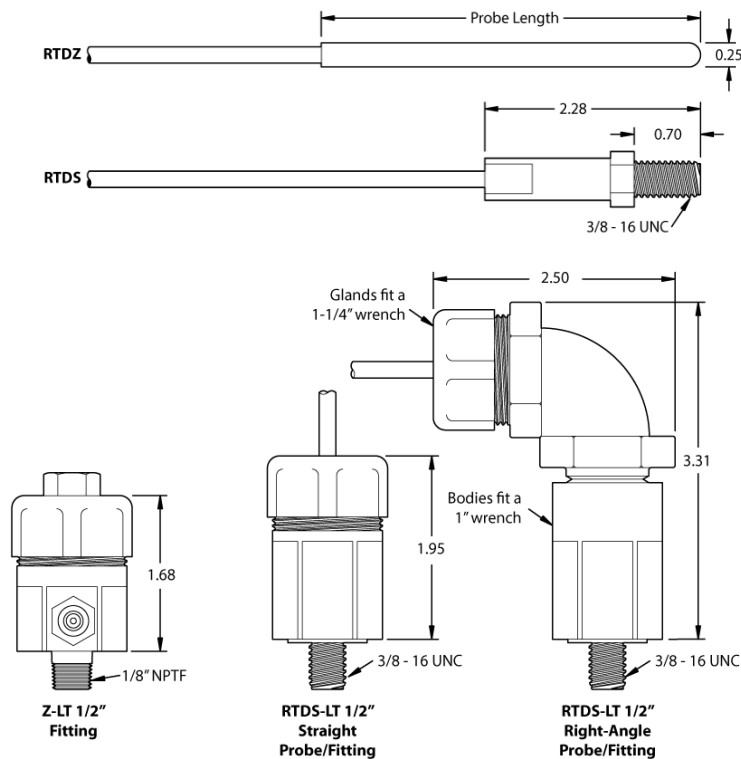

Specifications

Meas. range	(RTDZ/S)	-50 → 200 °C (-58 → 392 °F)
	(RTDZ/S-LT)	-50 → 150 °C (-58 → 302 °F) at the probe
Output signal		Resistance (Platinum Pt100 RTD, 100Ω @ 0 °C)
Temp coefficient (Alpha α)		0.385Ω/°C (at 0 °C)
Accuracy		Class B DIN (or better)
		Max error (°C) = ±(0.3 + 0.005*T)
Configuration		3-wire



R/T Relationship

(nominal):

$T \leq 0^\circ\text{C}$

$$R(T) = 100 [1 + 3.90802 \cdot 10^{-3} \cdot T - 0.5802 \cdot 10^{-6} \cdot T^2 - 4.27350 \cdot 10^{-12} (T - 100) T^3] \Omega$$

$T \geq 0^\circ\text{C}$

$$R(T) = 100 (1 + 3.90802 \cdot 10^{-3} \cdot T - 0.5802 \cdot 10^{-6} \cdot T^2) \Omega$$

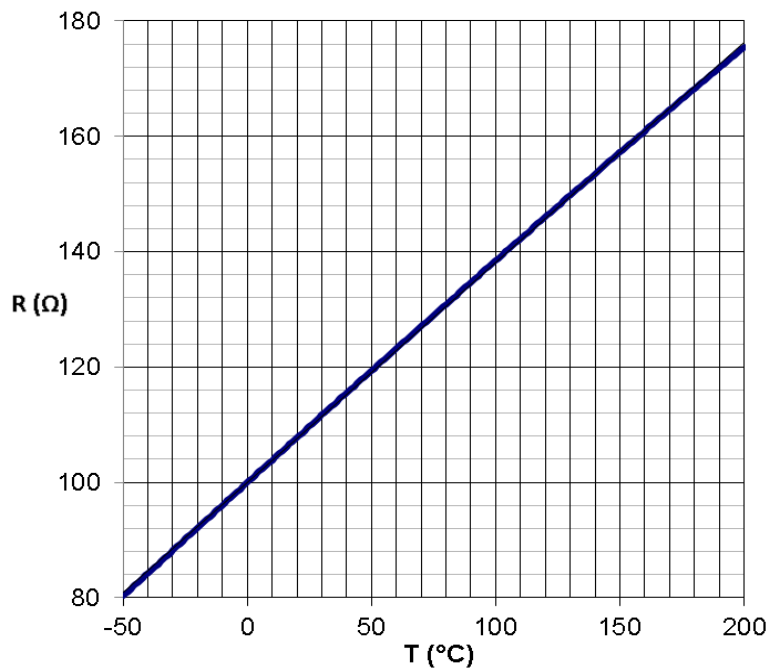

Model numbers

RTDZ (c ft, d in)

c: cable length in ft (10 standard), d: probe length in inches

RTDZ-LT (½ in, c ft, d in)

c: cable length in ft (10 standard), d: probe length in inches

RTDS (c ft)

c: cable length in ft (10 standard)

RTDS-LT (½ in, c ft, d)

c: cable length in ft (10 standard), d: straight or right-angle

Examples:

RTDZ (10 ft, 6 in)

RTDZ-LT (½ in, 10 ft, 4 in)

RTDS (20 ft)

RTDS-LT (½ in, 10 ft, straight)

RTDS-LT (½ in, 10 ft, right-angle)