

# Hall Effect Sensors

## Models 1101 and 931XP

### Description

Electro-Sensors' Model 931 and 1101 Hall Effect Sensors are designed for use with magnetic targets, such as our 60 Pole Pair Magnet Wheel, Heavy Duty Pulser Wraps, and Pulser Discs. The Model 931 Explosionproof Hall Effect Sensor is our standard Hall Effect Sensor mounted in a cast aluminum enclosure which is CSA approved and UL rated for Class I, Div 1, Groups C and D; Class II, Div 1, Groups E, F, and G. It also comes with 10 feet of 3-wire shielded cable and a mounting bracket. The enclosure conduit opening is threaded for 1/2 inch NPT.

The 1101 Hall Effect Sensor has a non-threaded stainless steel body, and is also supplied with a mounting bracket and 10' of cable. Electro-Sensors' model 1101 is the recommended Hall Effect Sensor for use with 60 Pole Pair Magnet Wheels and NEMA C Flange Ring Kits. The sensors can be mounted up to 1500 feet from the control unit, ie. speed switch, tachometer, etc.

Both the 931 and 1101 sensors can be powered by 5-25 Vdc and have an NPN open collector output. The Hall Effect Sensors switch high and low in the presence of alternating magnetic fields. This provides a squarewave (digital) signal with a 50/50 duty cycle when used with pulse generators that have evenly spaced magnets of alternating polarity such as Electro-Sensors' Pulse Generators. The gap distance between the sensing surface and the pulse generator depends on the strength of the target magnets. The signal produced by the sensors is compatible with all Electro-Sensors' products, most PLC digital I/O cards, and with other products requiring a digital pulse input signal.

### Pulser Disc

The end of the shaft to be monitored must be center drilled to a depth of 1/2 inch with a No. 21 drill and tapped for 10-32 UNF. After applying Loctite® or a similar adhesive on the threads to keep the pulser disc tight, the pulser disc should be attached decal side out with the supplied 10-32 UNF machine screw and lock washer. Discs can be used with either the 931 or 1101 sensor.

### Pulser Wrap

Pulser Wraps are custom manufactured to fit the shaft they will be mounted on. When the wrap is shipped, four Allen-head cap screws hold the two halves of the wrap together. These screws must be removed so that the wrap is in two halves. Place the halves around the shaft, reinsert the screws and torque them to 8 foot pounds. Pulser wraps can be used with either the 931 or 1101 sensor.

6111 Blue Circle Drive  
Minnetonka, MN 55343  
Phone: 952.930.0100  
Fax: 952.930.0130  
ISO 9001:2000 Certified



### Sensor Installation

The 1101 sensor is supplied with a mounting bracket and a set screw for position adjustment. The 931 explosionproof sensor is supplied with a slotted mounting bracket. Sensors should be installed so the center line of the magnets pass in front of the center of the sensor as the disc or wrap rotates. When using the pulser disc, the center of the magnetized area of the disc, shown as Dimension B in figures 1 and 3, is 1-3/4 inches from the center hole of the disc.

The recommended gap distance between the sensor and the disc or wrap, Dimension A in the diagrams, is 1/4 inch +/- 1/8 inch. To achieve the proper gap distance, adjust using the set screw holding the 1101 sensor in the mounting bracket, or adjust the position of the explosionproof sensor using the slots on its mounting bracket.

*Note: Gap distance is relative to the strength of the magnetic targets. Gap sensor for .020 on 60 pole pair magnet wheels.*

### Electrical Connections

The 931 and 1101 Hall Effect Sensors are designed for use with devices that have an internal pull-up resistor. If the device that will receive the signal does not have a pull-up resistor, a 2.2 K ohm resistor must be placed between the sensor supply voltage and the sensor signal output (see Wiring Diagram).

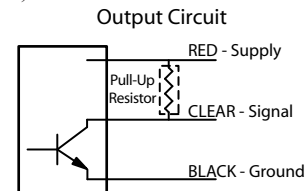

**Important Note:** Exercise caution when wiring the sensor, as damage will occur if the SIGNAL and SUPPLY lead wires are accidentally shorted. Carefully double-check all connections before applying power to the unit.

Free Catalog and Application Assistance  
1.800.328.6170  
Visit Us Online  
www.electro-sensors.com  
990-001400 Revision E

## Wiring Chart

Color	Connect To	Description
Red	Supply	Transducer Supply
White or Clear	Signal	Transducer Signal
Black	Circuit Ground	Transducer Ground
Shield	Circuit Ground	Transducer Ground

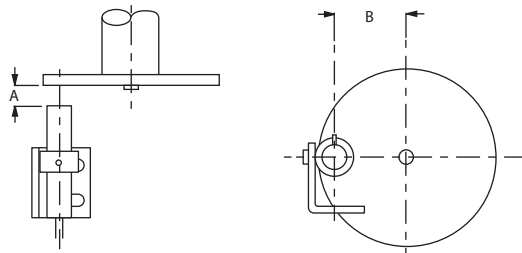

Figure 1: 1101 and Pulsar Disc

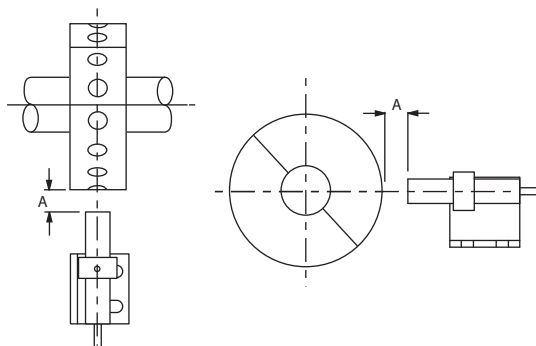

Figure 2: 1101 and Pulsar Wrap

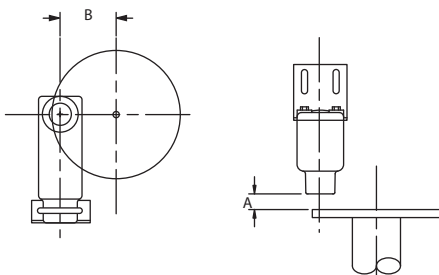

Figure 3: 931XP and Pulsar Disc

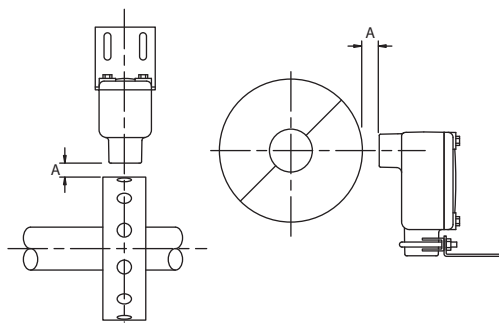

Figure 4: 931XP and Pulsar Wrap

## Sensor Specifications

Supply	5-25 Vdc
Output Type	NPN Open Collector
Current sink	25 mA Max
Operating Frequency	0 Hz to 20 kHz
Temp Range	-40° C to +65° C
Gap Distance	1/4 inch +/- 1/8 inch
Cable Length	10 feet standard (1500 feet max.)
Cable	3-Conductor, Shielded
Mounting Bracket	Plated Steel, Included
Body Material	<b>931XP:</b> Cast Aluminum <b>1101:</b> Stainless Steel



Class I, Div 1, Group C, D  
Class II, Div 1, Groups E, F, G  
UL File: E249019  
Sensor Model: 931



## Part Dimensions

### Model 931XP Sensor and Mounting Bracket

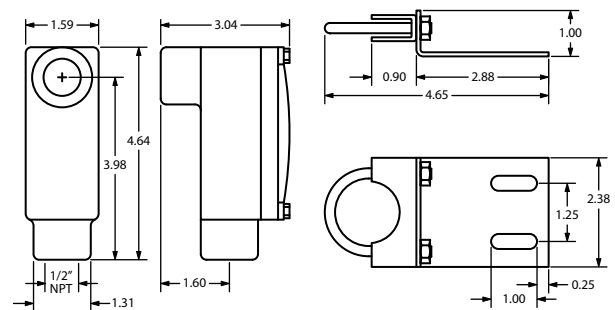

### Model 1101 Sensor

