

Operating Instructions

Radar sensor for continuous level measurement

CNCR-110

Two-wire 4–20 mA



BINMASTER.

Contents

1	About this document	3
2	For your safety	3
	2.1 Authorized personnel	3
	2.2 Appropriate use	3
	2.3 Warning about incorrect use	4
3	Product description	4
	3.1 Configuration	4
	3.2 Principle of operation	5
	3.3 Adjustment	5
4	Mounting	6
	4.1 General instructions	6
	4.2 Mounting versions	6
	4.3 Mounting instructions	6
5	Connecting to power supply	10
	5.1 Preparing the connection	10
	5.2 Wiring plan	10
6	Setup with smartphone/tablet (Bluetooth)	11
	6.1 Preparations	11
	6.2 Connecting	11
	6.3 Parameter adjustment	12
7	Menu overview	13
8	Diagnostics and servicing	14
	8.1 Maintenance	14
	8.2 Status messages	14
9	Removal	16
	9.1 Disposal	16
10	Certificates and approvals	17
	10.1 Radio licenses	17
11	Supplement	17
	11.1 Technical data	17
	11.2 Dimensions	19

1 About this document



Information, note, tip: This symbol indicates helpful additional information and tips.



Note: This symbol indicates notes to prevent failures, malfunctions, damage to devices or facility.



Caution: Non-observance may result in personal injury.



Warning: Non-observance may result in serious or fatal personal injury.



Danger: Non-observance of the information marked with this symbol will result in serious or fatal personal injury.



Ex applications

This symbol indicates special instructions for Ex applications.



List

The dot set in front indicates a list with no implied sequence.



Sequence of actions

Numbers set in front indicate successive steps in a procedure.



Battery disposal

This symbol indicates special information about the disposal of batteries and accumulators.

2 For your safety

2.1 Authorized personnel

All operations described in this documentation must be carried out only by trained, qualified personnel authorized by the plant operator.

Required personal protective equipment must always be worn when working on or with the device.

2.2 Appropriate use

CNCR-110 is a sensor for continuous level measurement.

Operational reliability is ensured only if the instrument is properly used according to the specifications in the operating instructions.

2.3 Warning about incorrect use

Inappropriate or incorrect use of this product can result in application-specific hazards, e.g. vessel overfill by incorrect mounting or adjustment. Damage to property, persons or environmental contamination can result.



Safety instructions for Ex areas

Take note of the Ex specific safety instructions for Ex applications.

These instructions are attached as documents to each instrument with Ex approval and are part of the operating instructions.

3 Product Description

3.1 Configuration

Constituent parts

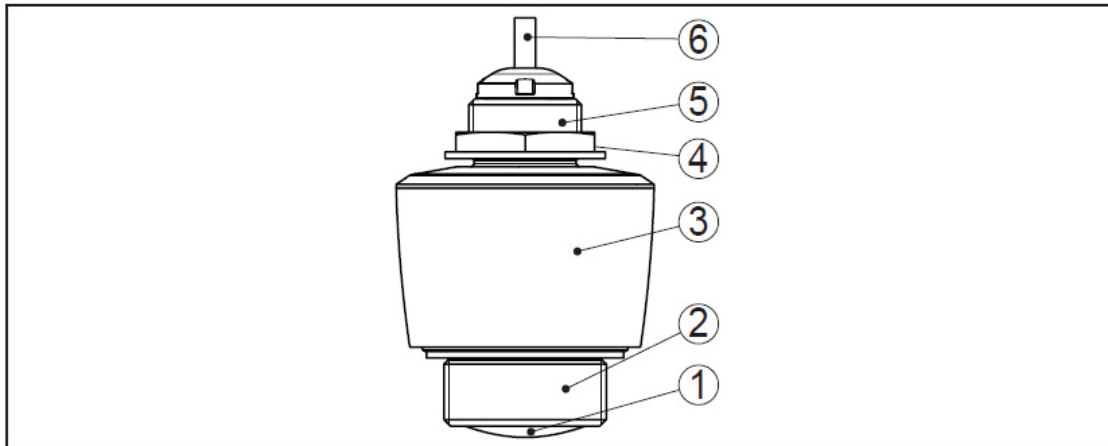

Fig. 1: Components of CNCR-110

- 1 Process fitting
- 3 Electronics housing
- 4 Mounting thread
- 5 Locking nut
- 6 Connection cable

3.2 Principle of operation

CNCR-110 is a radar sensor for continuous level measurement. It is suitable for liquids and solids in practically all industries.

The instrument emits a continuous, frequency-modulated radar signal from its antenna. The emitted signal is reflected by the material and received by the antenna as an echo with a modified frequency. The frequency change is proportional to the distance to the material.

3.3 Adjustment

Devices with integrated Bluetooth module can be adjusted wirelessly via software adjustment tools:

- Smartphone/tablet (iOS or Android operating system)
- PC/notebook with Bluetooth USB adapter (Windows operating system)

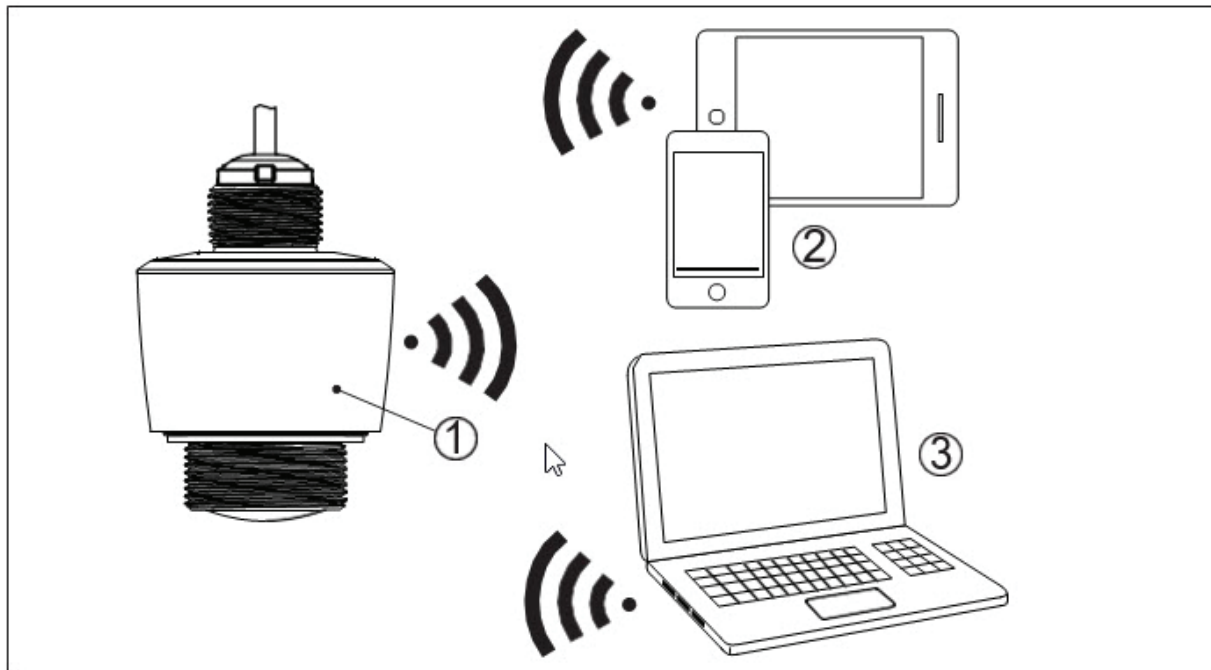

Fig. 2: Wireless connection to standard operating devices with integrated Bluetooth LE

- 1 Sensor
- 2 Smartphone/Tablet
- 3 PC/Notebook

4 Mounting

4.1 General instructions

The instrument is suitable for standard and extended ambient conditions according to DIN/EN/IEC/ANSI/ISA/UL/CSA 61010-1. It can be used indoors as well as outdoors.

4.2 Mounting

For a rigid mount, a mounting bracket with opening for thread G1 is recommended. The sensor is mounted in the bracket using the supplied G1 plastic nut. Take note of Figure 4 for the recommended minimum distance to the vessel wall.

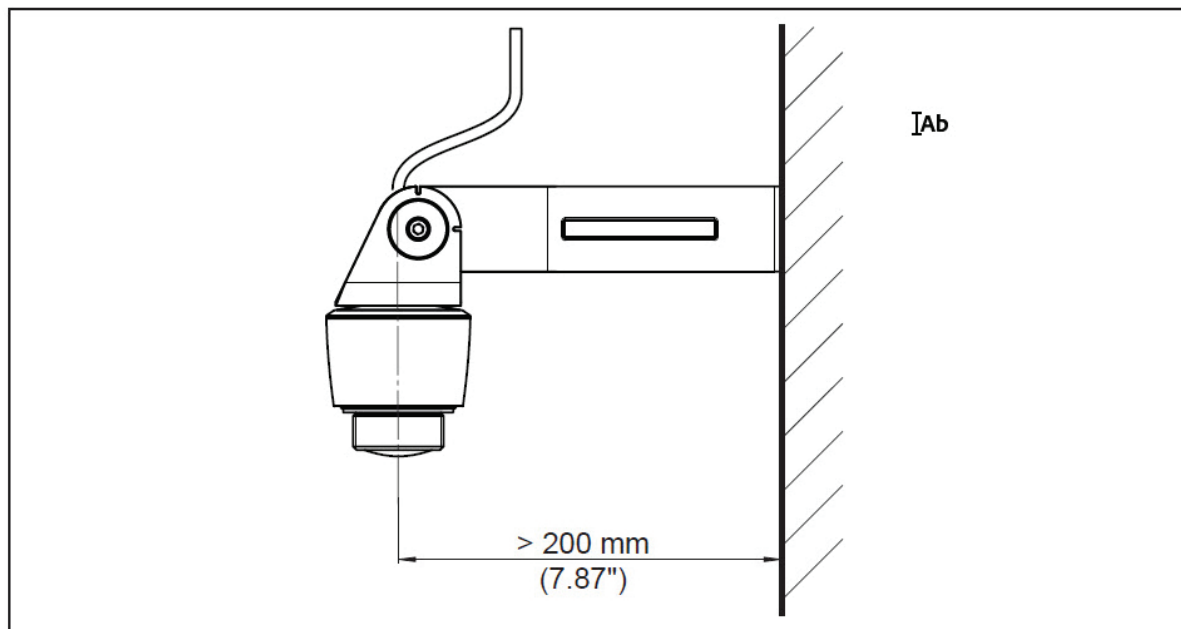

Fig. 3: Mounting via a mounting bracket

4.3 Mounting instructions

The radar emits pulses of electromagnetic waves which are polarized. By adjusting the rotation of the instrument the polarization can be changed to reduce false echoes.

The narrow portion of the radar signal is in the middle of the printed label on the instrument. This should be pointed towards the center of the vessel or any obstacle that may cause and unwanted reflections to minimize false echos, for example, the sidewall or vessel structure.

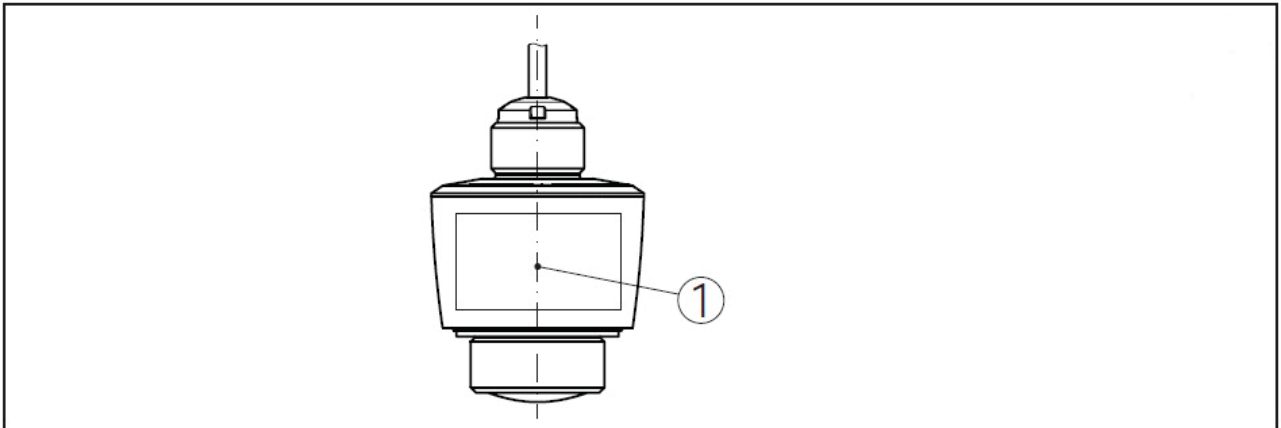

Fig. 4: Polarization position
1 Middle of the printed label

When mounting the sensor, distance it at least 200 mm (7.874 in) from the vessel wall. If the sensor is installed in the center of a round vessel top, multiple echoes can arise. However, these can be suppressed by a false signal suppression (see chapter “Setup”).

If you cannot maintain this distance, you should carry out a false signal suppression during initial setup. This applies particularly if buildup on the vessel wall is expected. If this is the case, we recommend repeating the false signal suppression later with the additional buildup.

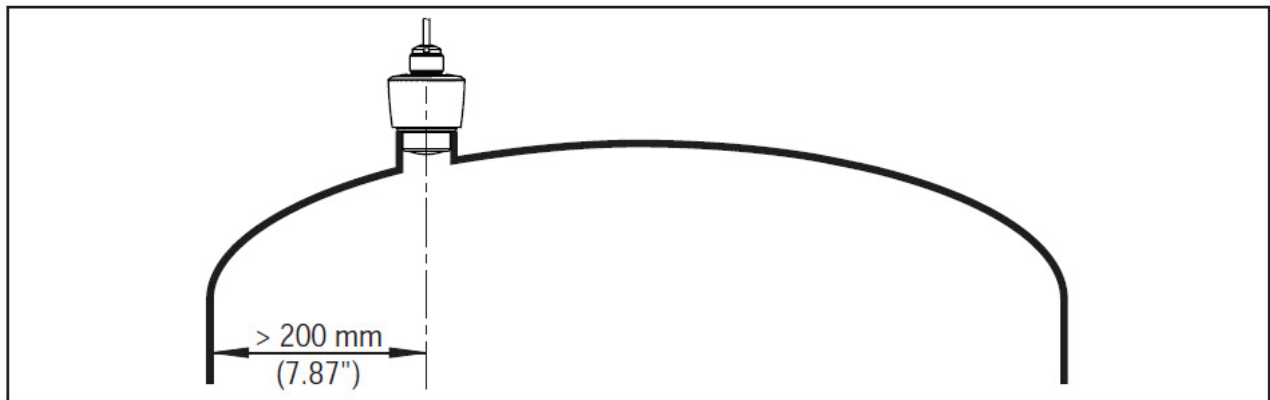

Fig. 5: Mounting the radar sensor on round vessel tops

In vessels with cone bottoms, the sensor can be mounted in the center of the vessel to measure material down to the outlet.

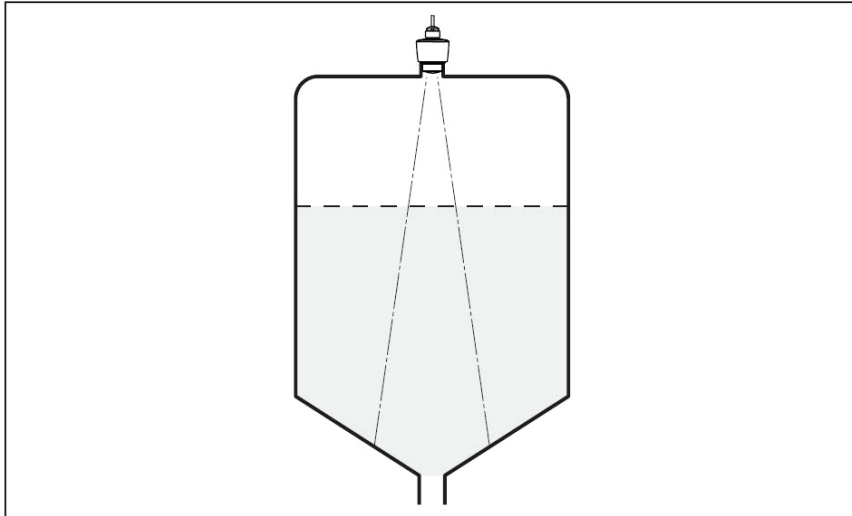

Fig. 6: Mounting the radar sensor with conical bottoms

Do not mount the instruments in or above the fill stream. Make sure that it is pointed towards the medium surface, not the fill stream.

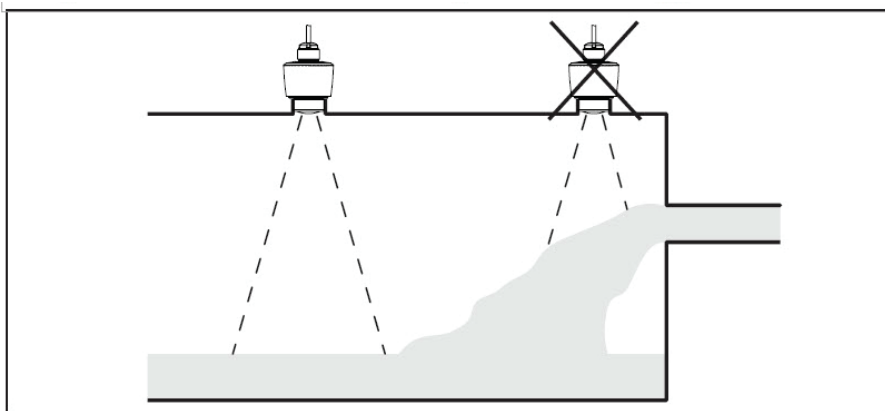

Fig. 7: Mounting the radar sensor away from fill stream

For socket or stand pipe mount, the pipe should be as short as possible and its bottom end rounded to reduce false reflections from the end of the pipe.

When using a threaded coupling, the antenna end should protrude at least 5 mm (0.2 in) out of the coupling.

If the reflective properties of the material are good, you can mount the CNCR-110 on sockets or stand pipes longer than the antenna. The pipe end should be smooth, burr-free and the end rounded.



Note:

When mounting on longer sockets or stand pipes, we recommend carrying out a false signal suppression after install (see chapter 6.3 “Parameter adjustment”).

Recommended values for socket or stand pipe lengths and heights are in the following table. The values come from typical applications.

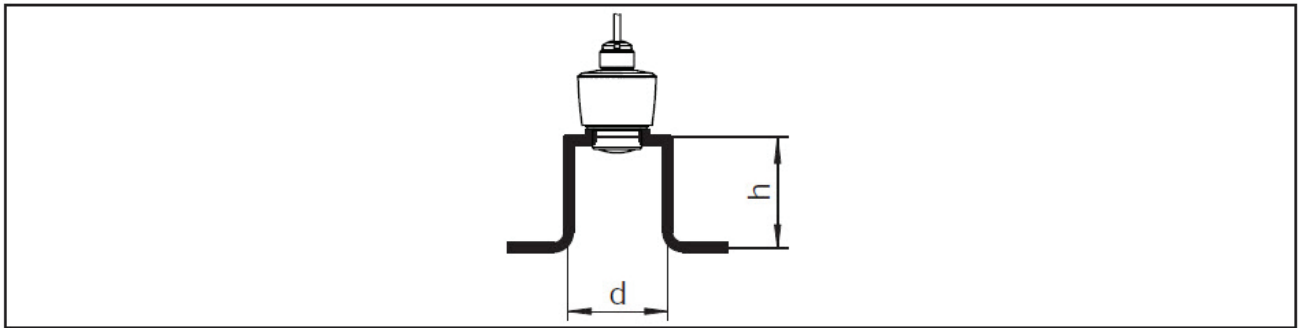

Fig. 8: Mounting the radar sensor with stand pipes

Socket diameter d		Socket length h	
40 mm	1½"	≤ 150 mm	≤ 5.9 in
50 mm	2"	≤ 200 mm	≤ 7.9 in
80 mm	3"	≤ 300 mm	≤ 11.8 in
100 mm	4"	≤ 400 mm	≤ 15.8 in
150 mm	6"	≤ 600 mm	≤ 23.6 in

The sensor should be mounted in a location where the radar signal is not interfered with by structure, such as ladders, braces or fill stream.

Make sure when planning the installation there is a clear, unobstructed view to the material to be measured. After installation a false signal suppression should be carried out to minimize any reflections from the mount or nearby structure.

5 Connecting to power supply

5.1 Preparing the connection

- Electrical connection should be completed by trained, qualified personnel
- Authorized by the plant operator
- If overvoltage surges are expected, overvoltage arresters should be installed

**Warning:**

Only connect or disconnect in de-energized state.

**Note:**

Power the instrument via an energy-limited circuit (power max. 100 W)
acc. to IEC 61010-1, e.g.

- Class 2 power supply unit (acc. to UL1310)
- SELV power supply unit (safety extra-low voltage) with suitable internal or external limitation of the output current

The device is supplied with a fixed cable. If an extension is required, a standard two-wire cable can be used.

5.2 Wiring Plan

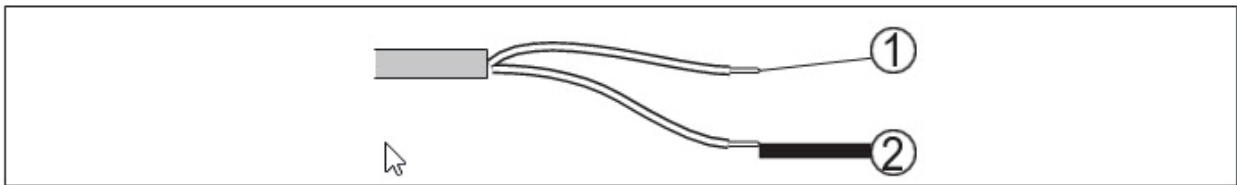

Fig. 9: Wire assignment in permanently connected connection cable

	Wire color	Function	Polarity
1	Brown	Voltage supply, signal output	Plus (+) 24 VDC
2	Blue	Voltage supply, signal output	Minus (-)

6 Setup with smartphone/tablet (Bluetooth)

6.1 Preparations

Make sure that your smartphone/tablet meets the following system requirements:

- Operating system: iOS 8 or newer
- Operating system: Android 5.1 or newer
- Bluetooth 4.0 LE or newer

Download the Wireless Device Configurator app from the “*Apple App Store*” or “*Google Play Store*” to your smartphone or tablet. To enable the Bluetooth software enter the BinMaster company ID code BMYQXZ.

6.2 Connecting

Start the adjustment app and select the function “Setup”. The smartphone/tablet searches automatically for Bluetooth-capable instruments in the area.

The message “*Connecting ...*” is displayed.

The devices found are listed and the search is automatically continued.

Select the requested instrument in the device list.

When establishing the connection for the first time, the smartphone/tablet and the sensor must authenticate each other. After the first correct authentication, each subsequent connection is made without a new authentication query.

For authentication, enter the 6-digit Bluetooth access code in the next menu window. You can find the code on the outside of the device housing.

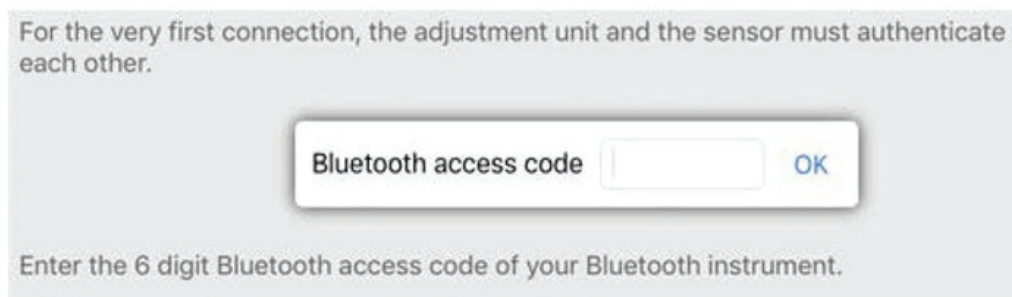

Fig. 10: Enter Bluetooth access code



Note:

If an incorrect code is entered, the code can only be entered again after a time delay and the delay gets longer after each incorrect entry. The message “Waiting for authentication” is displayed on the smartphone/tablet.

After the sensor is connected, the sensor adjustment menu is displayed on the smartphone/tablet.

If the Bluetooth connection is interrupted, e.g. due to a too large distance between the two devices, this is displayed on the smartphone/tablet. The message disappears when the connection is restored.

Parameter adjustment of the device is only possible if the parameter protection is deactivated, which is default. Parameter protection can be activated later if desired.

6.3 Parameter adjustment

The sensor adjustment menu is divided into two areas, which are arranged next to each other or one below the other, depending on the smartphone/tablet.

- Navigation section
- Menu item display

The selected menu item can be recognized by the color change.

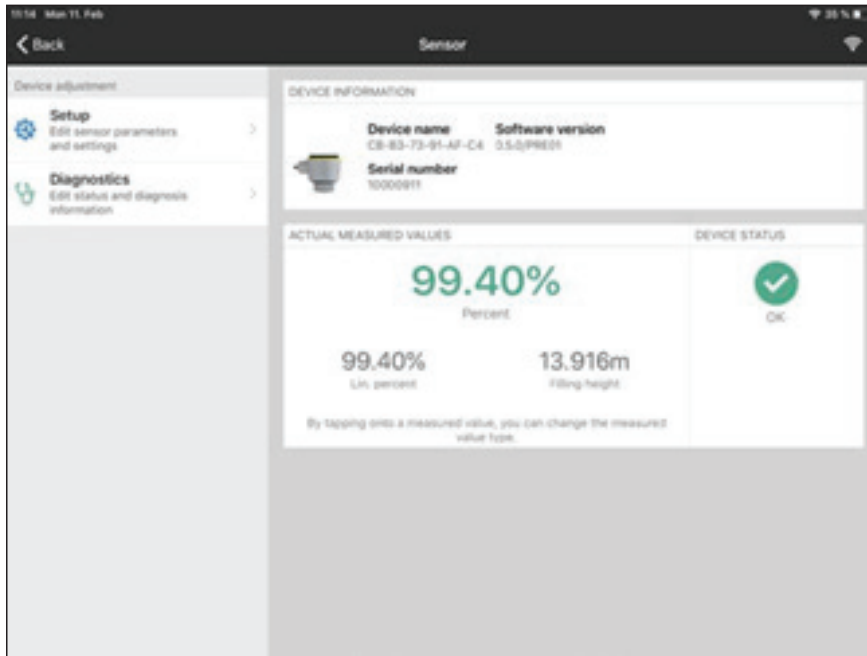

Fig. 11: Example of an app view - Setup sensor adjustment

Enter the requested parameters and confirm via the keyboard or the editing field. The settings are then active in the sensor.

Close the app to terminate connection.

i Note:

If the CNCR fails to connect to the Wireless Device Configuration App (WDCA) via Bluetooth, close the (WDCA), power cycle the CNCR and attempt to reconnect.

If further action is required, power cycle the Bluetooth on your device, and repeat the steps above.

7 Menu overview

Menu item	Selection	Default settings
Measurement loop name	Alphanumeric characters	Sensor
Medium	Liquid Bulk solid	Liquid
Application liquid	Storage tank, agitator tank, dosing tank, pumping station/pump shaft, rain overflow basin, tank/collection basin, plastic tank (measurement through tank top), mobile plastic tank (IBC), level measurement in waters, flow measurement flume/overflow, demonstration	Storage tank
Application bulk solid	Silo (slim and high), bunker (large volume), stockpile (point measurement/profile detection), crusher, demonstration	Silo (slender and high)
Units	Distance unit of the device Temperature unit of the instrument	Distance in ft. Temperature in °F
Adjustment	Max. adjustment (distance A) - 20mA (100%) Min. adjustment (distance B) - 4mA (0%)	Distance from sensor Max. adjustment 0.0 m Min. adjustment 8.0 m

Menu item	Selection	Default settings
Damping	Integration time	0 s
Current output	Output characteristics	4 to 20 mA = 0% to 100%
	Current range	Min. current 4 mA and max. current 20.5 mA
	Reaction when malfunctions occur	Failure mode < 3.6 mA
Linearization	Linearization type	Linear
Scaling	Scaling size Scaling unit Scaling format	0% correspond to 0 l 100% correspond to 100 l
Display	Menu language Displayed value Backlight	English Distance On
Access protection	Bluetooth access code	-
	Parameter Protection	Deactivated

Menu item	Selection	Default settings
False signal suppression	False signal suppression	0 m
	Sounded distance to the material	0 m
Reset	Delivery status, basic settings	-

Menu item	Selection	Default settings
Status	Sensor status Measured value status Status output Status additional measured values	-
Echo curve	Indication of echo curve	-

8 Diagnostics and servicing

8.1 Maintenance

If the device is used properly, no special maintenance is required in normal operation.

In some applications, buildup on the antenna system can influence the measurement. Depending on the sensor and application, be careful to avoid heavy soiling of the antenna system. If necessary, clean the antenna system periodically.

8.2 Status messages

The status messages are divided into the following categories:

- Failure
- Function check
- Out of specification
- Maintenance required

Failure

Code Text message	Cause	Rectification
F013 no measured value available	No measured value in the boot up phase or during operation	Check or correct installation and/or parameter settings Clean the antenna system
F017 Adjustment span too small	Adjustment not within specification	Change adjustment according to the limit values (difference between min. and max. ≥ 10 mm)
F025 Error in the linearization table	Linearization values are not continuously rising, for example illogical value pairs	Check linearization table Delete table/Create new
F036 No operable software	Checksum error if software update failed or aborted	Repeat software update Send instrument in for repair
F040 Error in the electronics	Limit value exceeded in signal processing Hardware error	Restart instrument Send instrument in for repair
F080 General software error	General software error	Restart instrument
F105 Determine measured value	The instrument is still in the boot up phase, the measured value could not yet be determined	Wait for the end of the boot up phase Duration up to 3 minutes depending on the measurement environment and parameter settings
F260 Error in the calibration	Checksum error in the calibration values Error in the EEPROM	Send instrument in for repair
F261 Error in the instrument settings	Error during setup False signal suppression faulty error when carrying out a reset	Repeat setup Reset instrument
F265 Measurement function disturbed	Program sequence of the measuring function disturbed	Device restarts automatically

Function check

Code Text message	Cause	Rectification
C700 Simulation active	A simulation is active	Finish simulation Wait for the automatic end after 60 mins.

Out of specification

Code Text message	Cause	Rectification
S600 Impermissible electronics temperature	Temperature of the electronics out of specified range	Check ambient temperature Insulate electronics
S601 Overfilling	Danger of vessel overfilling	Make sure that there is no further filling Check level in the vessel
S603 Impermissible operating voltage	Terminal voltage too low	Check terminal voltage, increase operating voltage

Maintenance

Code Text message	Cause	Rectification
M500 Error in the delivery status		
M501 Error in the delivery status		
M504 Error at a device interface	Hardware defect	Check connections Replace the electronics Send instrument in for repair
M505 No echo available	Sensor does not detect an echo during operation Antenna dirty or defective	Clean the antenna Use a more suitable antenna/sensor Remove possible false echoes Optimize sensor position and orientation
M507 Error in the instrument settings	Error during setup Error when carrying out a reset False signal suppression faulty	Reset instrument and repeat setup
M508 Data error in program memory Bluetooth controller		
M509 Software update		
M510 No communication with the sensor		

9 Removal

9.1 Disposal

The device is made of recyclable materials that can be disposed of by specialty recycling companies. Observe the applicable local regulations for proper disposal.

10 Certificates and approvals

10.1 Radio licenses

Radar

The device has been tested and approved in accordance with the current edition of the applicable country-specific norms or standards.

Bluetooth

The Bluetooth radio module in the device has been tested and approved according to the current edition of the applicable country-specific norms or standards.

11 Supplement

11.1 Technical data

Note for approved instruments

The technical data in the respective safety instructions which are included are valid for approved instruments (e.g. with Ex approval). These data can differ from the data listed herein, for example regarding the process conditions or the voltage supply.

Materials and weights

Materials, wetted parts

– Antenna, process fitting	PVDF
– Counter nut (depending on device version)	PP
– Process seal	FKM

Materials, non-wetted parts

– Housing	PVDF
– Cable entry seal	NBR
– Connection cable	PVC

Weight

– Instrument	0.7 kg (1.543 lbs)
– Connection cable	0.1 kg/m
Process fitting	Thread G1½, R1½, 1½ NPT
Mounting connection	Thread G1, R1, 1 NPT
Max. torque mounting boss	7 Nm (5.163 lbf ft)

Torques

Torque counter nut max.	7 Nm (5.163 lbf ft)
-------------------------	---------------------

Measurement Range

Measurement range	The measurement range is the distance between the antenna face of the sensor and the material surface. The antenna face is also the reference plane for the measurement.
-------------------	--

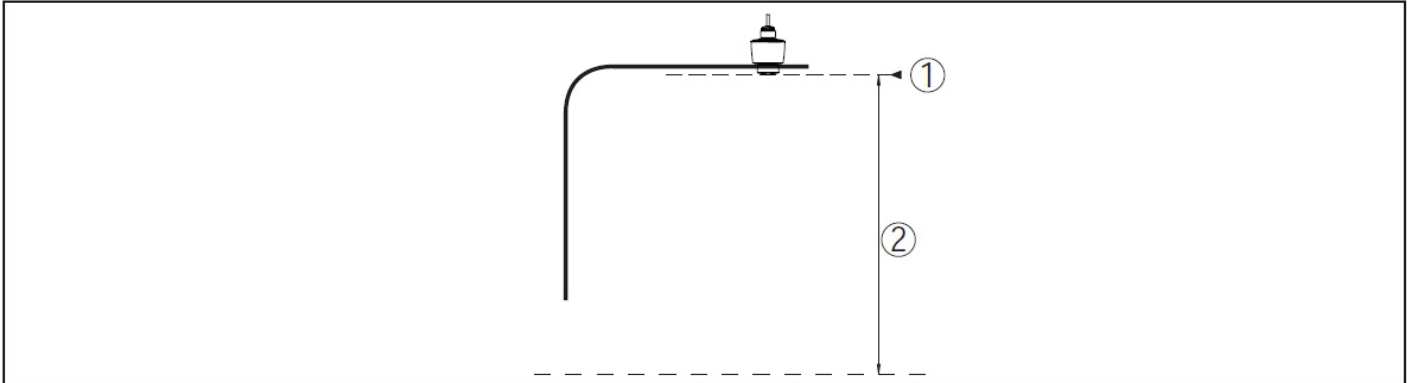

Fig. 12: Measurement Range

- 1 Reference plane
- 2 Measured value, max. measuring range

Max. measuring range	8 m (26.25 ft)
Recommended measuring range	up to 5 m (16.4 ft)

Output

Output signal	4 to 20 mA
Range of the output signal	3.8 to 20.5 mA (default setting)
Signal resolution	0.3 μ A
Resolution, digital	1 mm (0.039 in)
Fault signal, current output (adjustable)	≤ 3.6 mA, ≥ 21 mA, last valid measured value
Max. output current	22 mA
Load	See load resistance under Power supply
Starting current	≤ 3.6 mA; ≤ 10 mA for 5 ms after switching on
Damping (63 % of the input variable), adjustable	0 to 999 s

Ambient conditions

Ambient temperature	-40 to +60 °C (-40 to +140 °F)
Storage and transport temperature	-40 to +80 °C (-40 to +176 °F)

Process conditions

For the process conditions, please also note the specifications on the printed label. The lowest value (amount) always applies.

Process temperature	-40 to +60 °C (-40 to +140 °F)
Process pressure	-1 to 3 bar (-100 to 200 kPa/-14.5 to 43.51 psig)

Voltage supply

Operating voltage	
– at 4 mA	12 to 35 V DC
– at 20 mA	9 to 35 V DC
Reverse voltage protection	Integrated

Electrical protective measures

Protection rating	IP66/IP68 (3 bar) acc. to IEC 60529, Type 4P acc. to UL 50
Altitude above sea level	5000 m (16404 ft)
Protection class	III
Pollution degree	4

11.2 Dimensions

CNCR-110

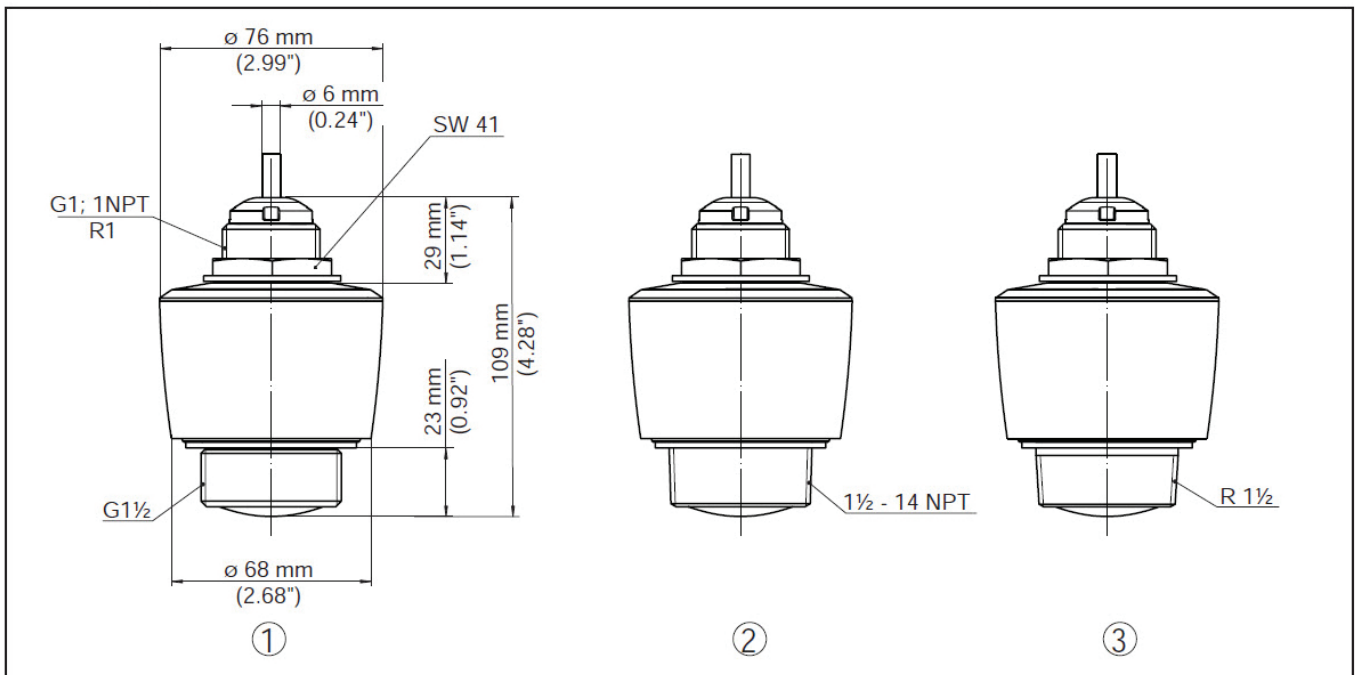

Fig. 13: Dimensions CNCR-110

- 1 Thread G1½
- 2 Thread 1½ NPT
- 3 Thread R1½

All statements concerning scope of delivery, application, practical use and operating conditions of the sensors and processing systems correspond to the information available at the time of printing.

Subject to change without prior notice.

BinMaster
7201 N 98th St.
Lincoln NE 68507
USA

Phone: 402-434-9102
Fax: 402-434-9133
E-mail: info@binmaster.com
www.binmaster.com