

DR1000 Digital Speed Switch

Precision Rotation Monitor

Principles of operation

The DR1000 monitors shaft speeds, and detects shaft slowdown within 1% of the set point. A DPDT control relay rated at 5 amps @ 30 Vdc and 120 Vac resistive, serving as the output. While the monitored shaft is rotating, the shaft mounted pulser disc or wrap generates a control signal that is detected by the sensor.

The signal is transmitted to the control unit via a 3-conductor shielded cable. At the control unit, the signal energizes a control relay. When the shaft drops below the trip point or stops rotating, the control signal de-energizes the relay. The switch is fail safe; any loss of power or loss of signal during the operation will de-energize the control circuit.

The system features a UL listed, heavy-duty explosionproof aluminum housing, containing the control relay, related circuitry, and a terminal block. It also includes a digital sensor with a 10-foot, 3-conductor shielded cable and a magnetic pulser disc.

Installing sensors

Pulser disc

The shaft end that will be monitored must be center drilled to a depth of 1/2-inch, with a No. 21 drill bit and tapped for 10-32UNF. Then apply Loctite® or a similar adhesive on the threads to keep the pulser disc tight. The pulser disc should be attached (*label side out*) with the supplied 10-32UNF machine screw and lock washer.

Pulser wrap (optional)

Pulser Wraps are custom manufactured to fit the shaft they will be mounted on. When the wrap is shipped, 4-Allen head cap screws hold the two halves of the wrap together. These screws must be removed so that the wrap is in two halves. Place the halves around the shaft, reinsert the screws, and torque them to 5 foot-pounds.

Installing sensors

The standard sensor is supplied with a mounting bracket and two jam nuts. The optional explosionproof sensor is supplied with a slotted mount bracket. Sensors should be installed so the centerline of the magnets pass in front of the center of the sensor as the disc or wrap rotates. When using the pulser disc, the center of the magnetized area of the disc, dimension B Figures 1 and 3, is 1-3/4 inches from the center hole of the disc.

The gap distance between the sensor and the disc or wrap, dimension A in all figures, is 1/4 inch \pm 1/8 inch. To achieve the proper gap distance with the standard sensor, adjust the jam nuts holding the standard sensor in its mounting bracket. To adjust the position of the explosionproof sensor, use the slots on its mounting bracket.

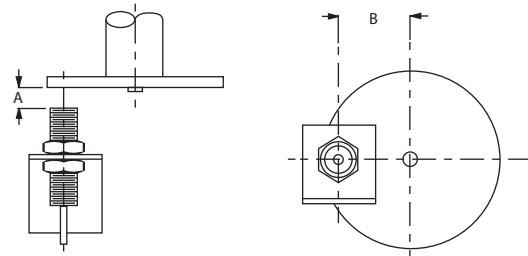

Figure 1: Standard 906 Sensor with 255 Pulser Disc

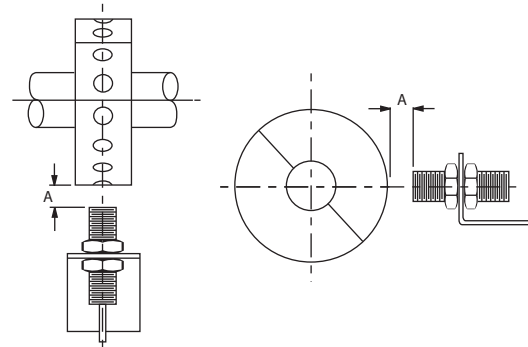

Figure 2: Standard 906 Sensor with optional Pulser Wrap

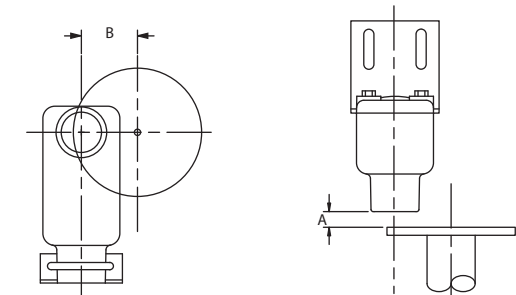

Figure 3: Explosionproof 907 Sensor with 255 Pulser Disc

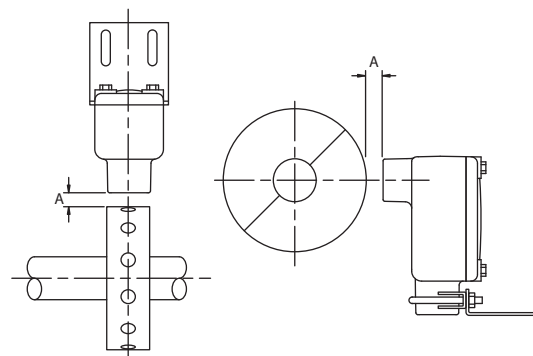

Figure 4: Explosionproof 907 Sensor with Pulser Wrap

Sensor Dimensions

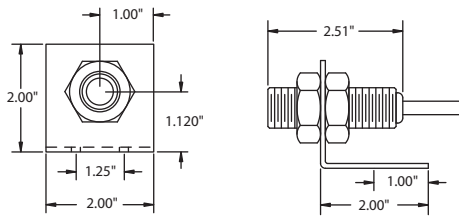

Figure 5: Standard 906 sensor dimensions

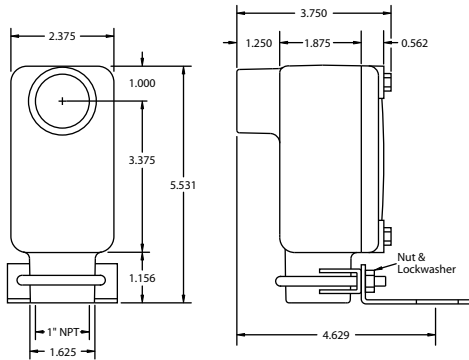

Figure 6: Explosionproof 907 Sensor dimensions

255 Pulser Disc and DR1000 Explosionproof enclosure dimensions

Figure 7 shows the dimensions of the 255 pulser disc.

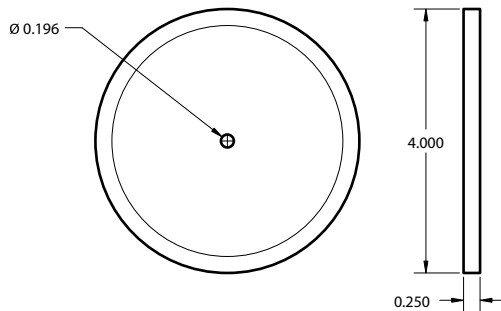

Figure 7: Disc Dimensions in Inches

Figure 8 shows the dimensions of the explosionproof enclosure.

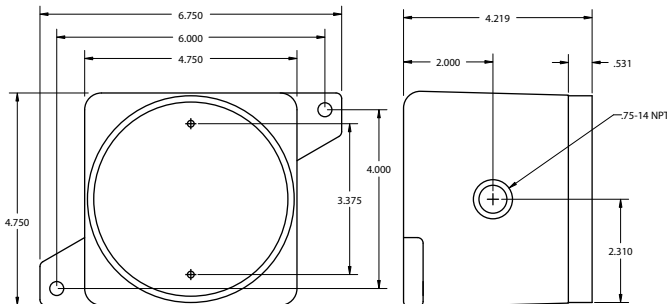

Figure 8: DR1000 Enclosure Dimensions in Inches

Mounting the enclosure

The enclosure can be mounted either horizontally or vertically

using two 1/4-inch bolts. The distance between the enclosure and the sensor can be up to 1500 feet. **DO NOT** mount the housing where water might enter it. Make sure that there is access to the terminal strip and switch adjustments.

Setup

Underspeed mode shaft running graph

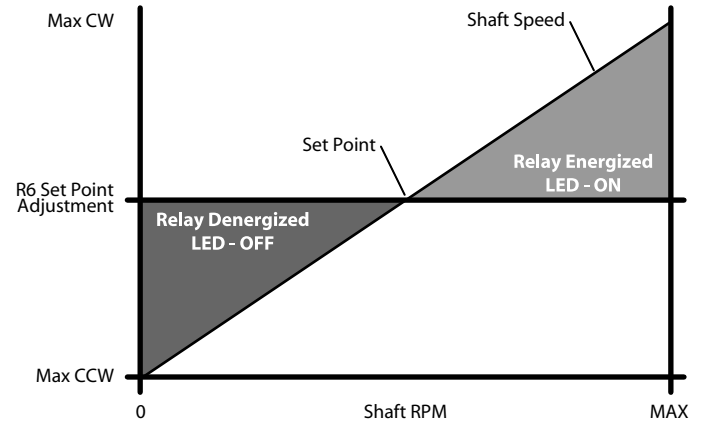

Calibrating the DR1000

1. With AC power OFF, turn the set point potentiometer, R6 on the DR1000 circuit board fully counterclockwise.
2. Determine the gross set point range of the shaft to be monitored.
3. Set the SW1 RPM position switches on the circuit board to the appropriate RPM setting for shaft rotation speed. See Table 1.
4. Apply AC power.
5. While the shaft is rotating at some known RPM, turn pot R6 on the circuit board slowly clockwise (CW) until the LED (CR1) turns OFF.
6. Turn pot R6 slowly counterclockwise (CCW) until the LED (CR1) turns ON.

The unit is now set to detect approximately a 4% to 5% reduction from the known RPM. For a set point trip at a speed reduction of more than 4% to 5% of a known RPM, continue to turn pot R6 CCW.

Note: For units wired for shutdown purposes, the relay contacts on the DR1000 can be bypassed during this procedure. If a bypass is used, it must be removed for proper operation once calibration is completed.

The DR1000 circuit board

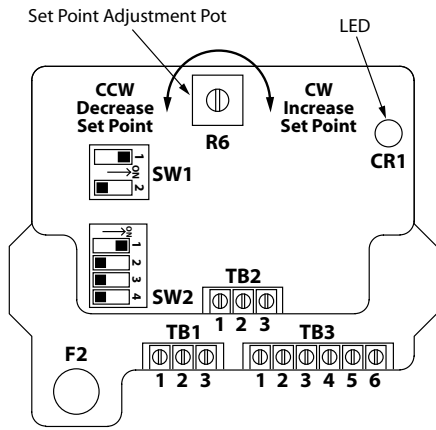

DR	Description
CR1	LED when relay is energized
R6	Set point pot. CW increase, CCW decrease (270° Single turn)
SW1	RPM range switch
SW2	Sensor type configuration
F2	Input Power Fuse, See specifications on back page

Figure 9: DR1000 Circuit Board

DR1000 wiring schemes for TB1, TB2, and TB3

TB1 is used to connect input power to the DR circuit board.

TB1			
Power	1	2	3
115 Vac	Line	Neutral	Ground
230 Vac	Line	Line	Ground
12 Vdc	Positive	Negative	Ground
24 Vdc	Positive	Negative	Ground

TB2 is used to connect ESI sensors to the DR circuit board.

Terminal	Sensor model 906/907	916A/917A	Other ESI Sensors Type NPN	ESI Prox Type NPN
1 Supply	Red	N/C	Red	Brown
2 Signal	Black	White	White	Black
3 Common	White/Shield	Black/Shield	Black/Shield	Blue

TB3 is used to connect the relay outputs to the DR circuit board

TB3					
1	2	3	4	5	6
NC1	COM1	NO1	NC2	COM2	NO2

DR SW1 RPM range switch setting table

SW1 Positions		
1	2	RPM Range
ON	ON	0.5 - 5*
OFF	ON	5 - 50
ON	OFF	50 - 500
OFF	OFF	500 - 5000

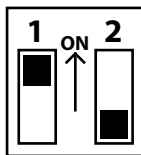

Note: The RPM range in the table above is approximate and for 8 PPR ONLY. You must rescale for other pulses per rev.

* Not available with two wire sensor input due to inadequate signal.

DR SW2 Sensor type

SW2 Positions	
For use with NPN output 3-wire sensors (ESI standard): Switch 1 is on and switches 2, 3, and 4 are off.	
For use with PNP output or Logic-Level sensors: Switch 1, 3 and 4 are off, and 2 is on.	
For use with magnetic pickup 2-wire sensors (ESI standard): Switch 1 is off and switches 2, 3, and 4 are on.	

Sample motor shutdown circuit

Figure 10 shows a typical wiring diagram for a Motor Shutdown Control circuit with an alarm for a digital speed switch such as the DR1000.

Disclaimer

The circuit shown in Figure 10 is provided for REFERENCE ONLY. Electro-Sensors accepts no responsibility for the use of this circuit or any circuit used for the purpose of Motor Shutdown.

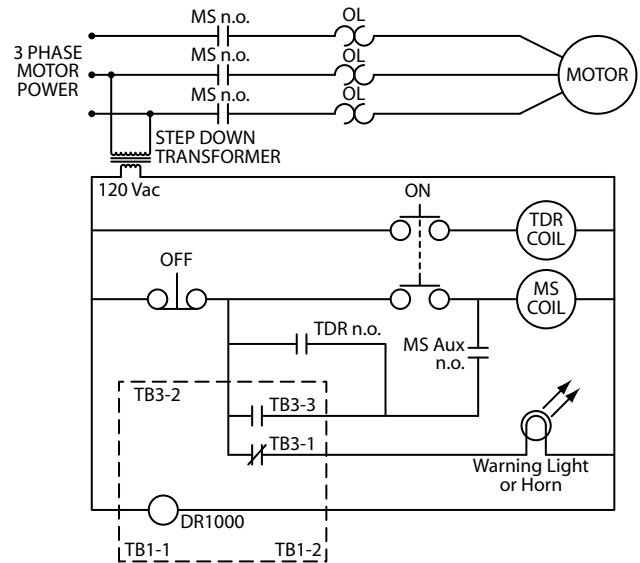

Figure 10: Sample Reference Motor Shutdown Circuit

Wiring diagram keys:

MS	Motor starter (not supplied)
OL	Overload contacts
n.o.	Normally open (relay is in a de-energized state)
TDR	Time delay OFF relay is not supplied. If the shaft being monitored comes up to speed slowly, a TDR can be used so the operator will not have to hold the START button in.

WARNING!

During a stopped condition, any slight movement of the shaft or magnetic disc could energize the control relay and start the motor—if the Motor Auxiliary Normally Open Contact (MS Aux n.o.) is not wired in series as shown Figure 10, the reference circuit. Failure to observe this warning could result in damage to the equipment or injury to persons. Always use proper Lock-Out-Tag-Out procedures.

Troubleshooting



Problem: Relay will not energize, the LED does not light up	
Possible Cause	Possible Solution
AC power is not applied to the DR1000 terminals correctly	Check input power @ TB1
Sensing head is not aligned or gapped properly	See figures 1 through 4, page 1
The set point is not in the proper range	See switch settings, page 3
The set point pot (R6) is not turned fully counterclockwise	See calibrating the DR1000, page 2
Shaft is not turning faster than the set point	Check actual rpm
Sensing head is not wired correctly to the DR speed switch	Check wiring @ TB2, page 3
There is no 12 Vdc sensor supply voltage	Check TB2-1 and TB2-3, page 3
The DR is not receiving a 12 volt square wave signal	Check TB2-2 and TB2-3, page 3

DR1000 speed switch specifications

Input Power	Input Current	Fuse Type (F2)
115 Vac, 50/60Hz (std)	1/16 Amp	Sloblo .063A 5X20
230 Vac, 50/60Hz (opt)	1/32 Amp	Sloblo .032A 5X20
12 Vdc (opt)	1/8 Amp	Sloblo .125A 5X20
24 Vdc (opt)	1/8 Amp	Sloblo .125A 5X20

Input Signal	Parameters
Type	NPN open collector, 2 wire, mag pickup, PNP, Logic.
Amplitude	12 V nom., 8 V min., 40 V max.
Pull-Up	2.2 K ohms
Repeatability	0.5%
Max Frequency	666 Hz (5000 RPM @ 8 PPR)
Min. Pulse Width	750 µsec



Relay Output Data	Parameters
Number Available	1 DPDT Form C
Actuation	Energized when shaft speed is above set point
Relay Contact Rating	5 Amp @ 30 Vdc, or 120 Vac resistive

Physical/Environment	Parameters
 Class I, Div 1, Group C, D Class II, Div 1, Group E, F, G UL File: E249019 	
Enclosure Dimensions	See Figure 8
Enclosure Material	Cast Aluminium, NEMA 4X
Operating Temperature	-40°C to +65°C*
Storage Temperature	-40°C to +65°C*
Shipping Weight	7 lbs

255 Pulser Disc (std.)	Parameters **
Material	Nylon 12 Std, (opt; PVC, Alum, Stainless-Steel)
Dimensions	4-inch diameter x 1/4-inch thick
Operating Temperature	-40°C to +60°C* (Nylon, PVC)
Operating Temperature	-40°C to +150°C* (Alum, SS)

Pulser Wrap (optional)	Parameters **
Material	PVC Std. (opt; Aluminum or Stainless-Steel)
Operating Temperature	-40°C to +60°C* (PVC)
Operating Temperature	-40°C to +150°C* (Aluminum, SS)

906 Sensor (Standard)	Parameters **
Material Sensor Body	Aluminum 3/4 - 16UNF thread
Material Mount Bracket	Plate steel
Output Types	NPN open collector current sinking 20 mA max
Signal Cable	3-conductor shielded, 10 feet length std. (50 ft. or 100 ft. optional)
Operating Temperature	-40°C to + 60°C*
Air Gap	1/4 inch +/- 1/8 inch

907 Explosionproof Sensor (optional)	Parameters **
 Class I, Div 1, Group D Class II, Div 1, Groups E, F, G UL File: E249019 	
Mounting Bracket Material	Plate Steel U-Bolt Assembly
Other Specifications	Similar to 906 standard sensor

Specifications are subject to change without notice.

***For higher or lower temperature ranges, consult factory.**

**** For details on Discs, Wraps and Sensors, consult factory or visit our website.**

