

# SA420 Signal Conditioner

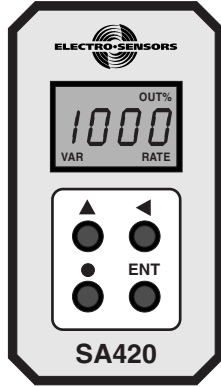

## Description:

Electro-Sensor's SA420 Signal Conditioner provides an analog signal directly proportional to the speed of a monitored shaft. The 0-10 VDC and 4-20 mA outputs can be sent to a chart recorder, digital display, PLC, loop controller, drive speed controller, or other control or monitoring devices. The wide voltage range and wave shape flexibility of the SA420's sensor input circuitry allow it to translate signals from Hall-Effect Sensors, proximity switches, magnetic sensors, and a wide variety of other pulse generator devices into analog outputs.

## Sensor Installation:

The standard sensor is supplied with a mounting bracket and two jam nuts. The explosion-proof sensor is supplied with a slotted mounting bracket. Sensors should be installed so the centerline of the magnets pass in front of the center of the sensor as the disc or wrap rotates. When using the pulser disc, the center of the magnetized area of the disc, shown as Dimension B in figures 1 and 3, is 1-3/4 inches from the center hole of the disc. The gap distance between the sensor and the disc or wrap, Dimension A in the diagrams, is 1/4-inch  $\pm$  1/8 inch. To achieve the proper gap distance, adjust the jam nuts holding the standard sensor in the mounting bracket, or adjust the position of the explosion-proof sensor using the slots on its mounting bracket.

## Pulser Disc:

The end of the shaft to be monitored must be center drilled to a depth of 1/2-inch with a No. 21 drill and tapped for 10-32UNF. After applying Loctite™ or a similar adhesive on the threads to keep the pulser disc tight, the pulser disc should be attached, decal side out, with the supplied 10-32UNF machine screw and lock washer.

## Pulser Wrap (optional):

Pulser Wraps are custom manufactured to fit the shaft they will be mounted on. When the wrap is shipped, four Allen-head cap screws hold the two halves of the wrap together. These screws must be removed so that the wrap is in two halves. Place the halves around the shaft, reinsert the screws and torque them to 5 foot-pounds max.

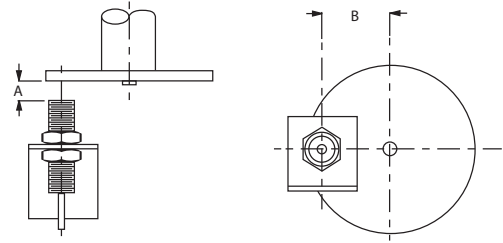

Figure 1: Standard Sensor with 255 Pulser Disc

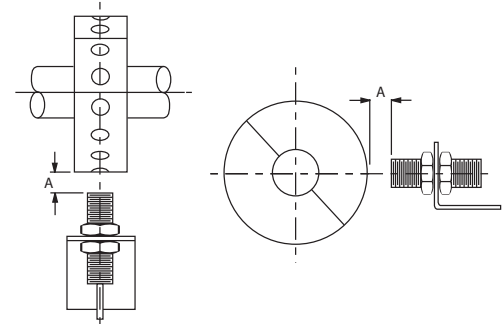

Figure 2: Standard Sensor with optional Pulser Wrap

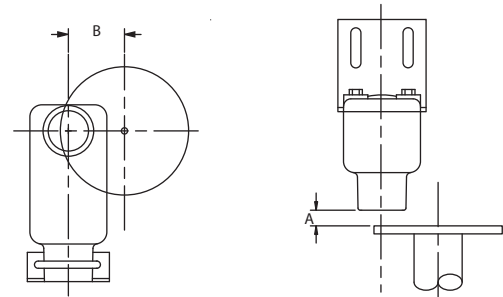

Figure 3: Explosionproof Sensor with 255 Pulser Disc

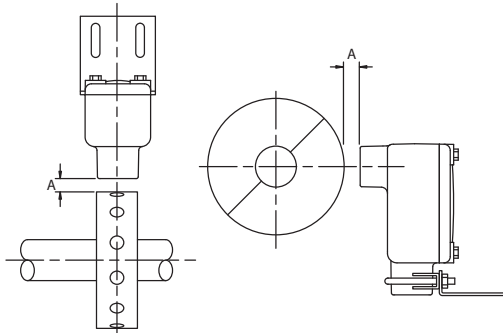

Figure 4: Explosionproof Sensor with Pulser Wrap

## Wiring Connections:

### Sensor Wire connections:

Terminal	Model 906/907	All other ESI Sensors	Mag Pickup	Logic Level	ESI Prox
5 Supply	Red	Red	N/C		Brown
6 Signal	Black	Clear	+	Signal	Black
7 Ground	Clr/Shd	Blk/Shd	-	Common	Blue

### Power Connections:

Terminal	115 VAC Standard	230 VAC Optional	12 VDC Optional	24 VDC Optional
2	Hot	L1 Hot	(+)Positive	(+)Positive
10	Neutral	L2 Hot	(-)Negative	(-)Negative

### Analog Output Connections:

Terminal	4-20 mA
3	(+) High
4	(-) Low

Terminal	0-10 VDC
9	(+) Positive
8	(-) Negative

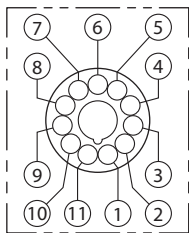

Terminal	Connection
1	No Connect
2	Hot +
3	4-20mA +
4	4-20mA -
5	Sensor Supply
6	Sensor Signal A
7	Sensor Ground
8	0-10 VDC -
9	0-10 VDC +
10	Neutral -
11	Sensor Signal B*

\*Advanced mode allows for bidirectional sensing. See website for addendum on using the SA420 in advanced mode.

Figure 5: Terminal Block wiring

### Calibration:

There are four buttons on the front panel used for calibration:

▲ Up Arrow Button is used to change the value of the position in focus (flashing), while in the calibration mode. While in standard mode, this button will toggle the display between frequency input (hertz) and output percentage.

◀ Left arrow button is used to move the focus to the next position when in the calibration mode of 4-20 mA or 0-10 VDC.

● Decimal Point Button is used to change the position of the decimal point while in the calibration mode.

ENT Enter Button is used to enter or exit the calibration mode.

**Variable 1** is used to set the maximum frequency, which will equal 100% output (10 VDC or 20 mA); 4 mA or 0 VDC is always equal to .01 Hz. The default value for variable 1 is 240.0 Hz. With the standard sensor and disc, this is equal to 1800 rpm at 8 pulses per revolution. Maximum Frequency = (RPM X PPR) / 60

**Variable 2** is used to select your sensor output type. The default is set to 0. *\*(All Standard ESI sensors are NPN open collector output.)*

Variable 2 value	Type of Sensors
0	NPN*
1	PNP
2	Magnetic Pickup
3	Logic Level

**Variable 3** is used for analog filtering. The number entered here represents the number of pulses that are to be averaged. The greater the number the smoother the output. The down side to a large number is response will suffer at lower speeds. Valid numbers are 1 to 250. The factory default is 8.

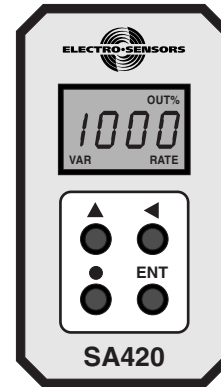

### Calibrating The Unit:

To enter the calibration mode, push the ENT button once. PR1 will be displayed for one second, and then the value of variable 1 is displayed. The right most digit of variable 1 will be flashing, which indicates that this digit has the focus and can be changed. Pressing the ▲ button will increment the flashing digit. The ◀ button will advance the focus to the next digit to be changed. The ● (DP) button will scroll the decimal point across the display from right to left. When the correct value is programmed into the variable, press the ENT button to store the variable in memory and access variable 2. You can now change the sensor output type if necessary or press the ENT button to return to standard mode.

**SA-420 Dimensional Drawings:**  
**Dimensions in Inches**

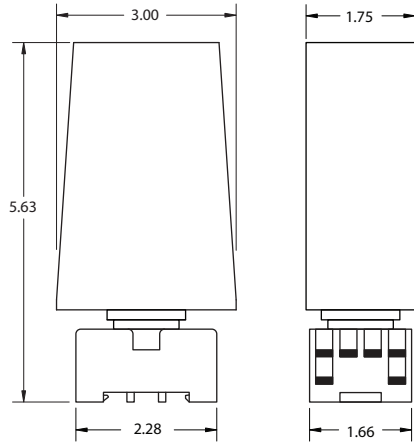

**Figure 6: SA-420**

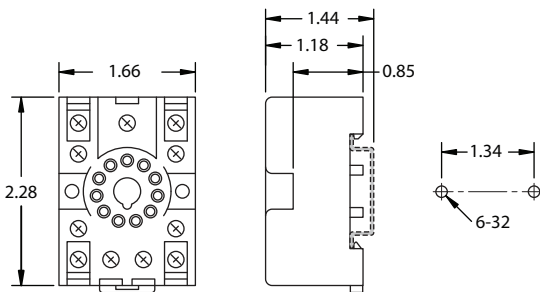

**Figure 7: Terminal Block**

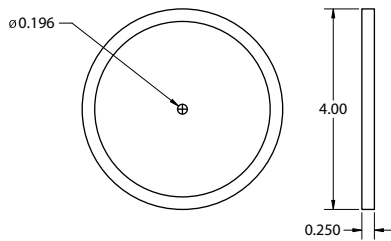

**Figure 8: 255 Pulsar Disc**

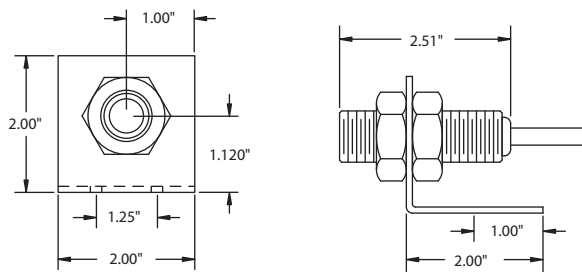

**Figure 9: Standard Sensor**

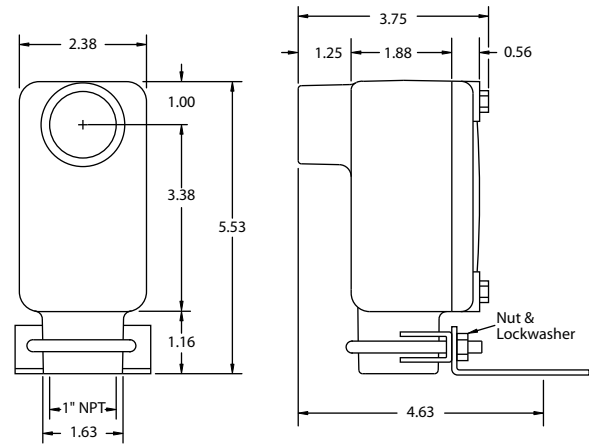

**Figure 10: Explosionproof Sensor**

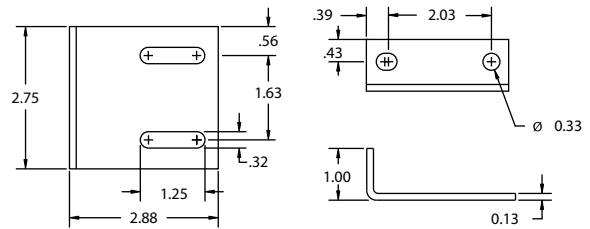

**Figure 11: Explosionproof Sensor Bracket**

## Troubleshooting Guide

Problem	Possible Solution
Unit Dead	Check for proper supply at terminals 2 and 10. See figure 5 on page 2
No Analog out with zero hertz displayed	Check for Sensor supply. It should be Approximately 13.6 VDC
	Check sensor Gap distance
	Check Sensor Type (Variable 2)
Unit displays a frequency but the analog is incorrect	Check variable 1 for correct frequency
	Check your on the correct analog output, voltage(VDC) or current(mA)
Analog is unstable	Check gap distance

### SA420 General Specifications:

Input Power	Input Current	Fuse Type (F2)
115 Vac, 60Hz (std)	2.5 VA	Sloblo .032A 5X20
230 Vac, 60Hz (opt)	2.5 VA	Sloblo .032A 5X20
12 Vdc (opt)	165 mA	Sloblo .250A 5X20
24 Vdc (opt)	135 mA	Sloblo .200A 5X20

Input Signal	Parameters
Sensor Supply	12 VDC (unregulated) @50 mA max.
Programmable Types	Open collector NPN / PNP Logic Level 5 V Nom. 3 V Min. Magnetic Sensor +/- 75 MV Min.
Max. Amplitude	25 Vpk-pk Maximum
Frequency Range	0.01 Hz to 10 kHz
Minimum Input for Full Scale Output	0.5 Hz = 3.8 RPM @ 8 PPR (Lower full scale range is available, consult Factory)

Analog Output Signal	Parameters
Types	0 - 10 VDC, 4 - 20 mA with 500Ω load max.
Accuracy (typical)	0.1% Linearity for both outputs



Step Response Time	Parameters
50 Hz Input and above	10 to 90% = 50 ms.
Below 50 Hz Input	10 to 90% = 30 ms + 1/Hz Input frequency

Physical/Environment	Parameters
Mounting	DIN rail mount or Stand alone
Operating temperature	0°C to +60°Cz
Storage temperature	-65°C to +125°C
Electrical Connections	11 Position DIN rail terminal block
DIN rail enclosure rating	NEMA 1

255 Pulser Disc (std.)	Parameters **
Material	Nylon 12 Std, (opt; PVC, Alum, Stainless-Steel)
Dimensions	4-inch diameter x 1/4-inch thick
Operating Temperature	-40°C to +60°C* (Nylon, PVC)
Operating Temperature	-40°C to +150°C* (Alum, SS)

Pulser Wrap (optional)	Parameters **
Material	PVC Std. (opt; Aluminum or Stainless-Steel)
Operating Temperature	-40°C to +60°C* (PVC)
Operating Temperature	-40°C to +150°C* (Aluminum, SS)

906 Sensor (Standard)	Parameters **
Material Sensor Body	Aluminum 3/4 - 16UNF thread
Material Mount Bracket	Plate steel
Output Types	NPN open collector current sinking 20 mA max
Signal Cable	3-conductor shielded, 10 feet length std. (50 ft. or 100 ft. optional)
Operating Temperature	-40°C to + 60°C*
Air Gap	1/4 inch +/- 1/8 inch with standard 255 Pulser disc (1/2" magnets)

907 Explosionproof Sensor (optional)	Parameters **
	Class I, Div 1, Group D Class II, Div 1, Groups E, F, G UL File: E249019
	
Mounting Bracket Material	Plate Steel U-Bolt Assembly
Other Specifications	Similar to 906 standard sensor

**Specifications are subject to change without notice.**

**\*For higher or lower temperature ranges, consult factory.**

**\*\* For details on Discs, Wraps and Sensors, consult factory or visit our website.**