

# DMS-100/5000

## DIN-Rail Mountable Speed Switch

### Description

The DMS-Series speed switch is an economical choice designed primarily for OEM use on machinery requiring shaft speed monitoring. Housed in a compact plastic enclosure, it mounts on a standard 35 mm DIN-rail and operates on 115/230 VAC with optional DC units available. The unit is switch selectable for NPN, PNP, mag sensor and logic level sensor inputs. Two models offer set point ranges from 5-5000 RPM. The set points are adjustable via two (2)25-turn potentiometers located under the housing cover. Both set points are switch selectable for over-or under-speed operation. A viewable LED indicates the relay status for easy trouble shooting. The DMS-Series is typically used to detect a slowdown on conveyors, fans, blowers and other machinery where a reduction in shaft speed rotation could adversely affect plant operations. Electro-Sensors' Speed Switches bring efficiency and safety to your operations by preventing machine damage, product waste and costly downtime.

### Principles of operation

The DMS-Series switch is supplied with a shaft mounted magnetic disc or wrap which generates a control signal that is picked up by the non-contact sensor. The sensor transmits this speed signal (frequency) back to the control unit via a 3-conductor shielded cable. At the control unit, the signal is compared with its adjustable set points, with choice of under speed or over speed mode. When the control signal is above the set point, in under speed mode, the relay is energized and de-energizes when the signal drops below the set point. In over speed mode the relay is energized when the control signal is below the set point and de-energizes when the signal goes above the set point. The switch is fail safe, any loss of power during operation will de-energize the relays.

### Pulser disc

The end of the shaft to be monitored must be center drilled to a depth of 1/2 -inch with a No. 21 drill and tapped for 10-32UNF. After applying Loctite® or a similar adhesive on the threads to keep the pulser disc tight, the pulser disc should be attached, decal side out, with the supplied 10-32UNF machine screw and lock washer.

### Pulser wrap (optional)

Pulser Wraps are custom manufactured to fit the shaft they will be mounted on. When the wrap is shipped, four allen-head cap screws hold the two halves of the wrap together. These screws must be removed so that the wrap is in two halves. Place the halves around the shaft, reinsert the screws and torque them to 8 foot pounds.

### Switch Selection Table:

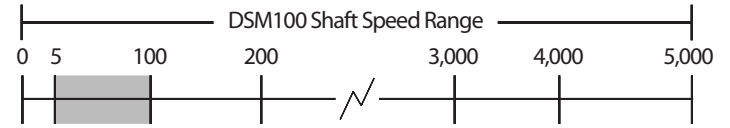

DMS100 Adjustable Set Point Range 5-100 RPM

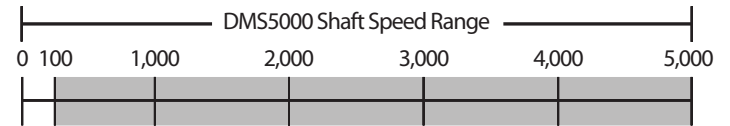

DMS5000 Adjustable Set Point Range 100-5000 RPM

### Installing sensors

The standard sensor is supplied with a mounting bracket and two jam nuts. The optional explosionproof sensor is supplied with a slotted mount bracket. Sensors should be installed so the centerline of the magnets pass in front of the center of the sensor as the disc or wrap rotates. When using the pulser disc, to find the center of the magnetized area of the disc, dimension B, See Table below.

The gap distance between the sensor and the disc or wrap, dimension A in all figures, is 1/4 inch ± 1/8 inch. To achieve the proper gap distance with the standard sensor, adjust the jam nuts holding the standard sensor in its mounting bracket. To adjust the position of the explosionproof sensor, use the slots on its mounting bracket.

### Sensing Surface Gap Distance Table

(Seeing Figures 1 and 2, below)

Model No.	Dimension "A" (inches)	Dimension "B" (inches)
DMS100	1/8" to 3/8"	1-3/4"
DMS5000	1/8" to 3/8"	7/8"

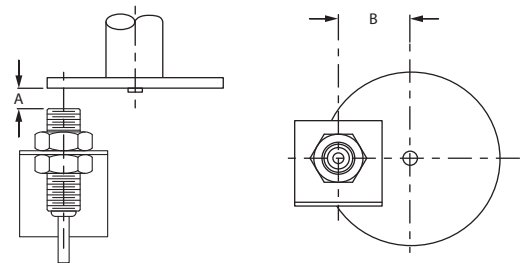

Figure 1: Standard 906 Sensor with Pulser Disc

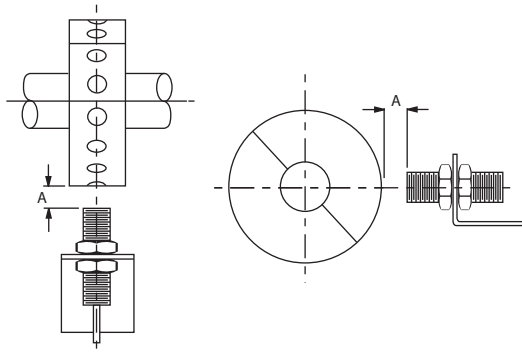

Figure 2: Standard 906 Sensor with optional Pulser Wrap

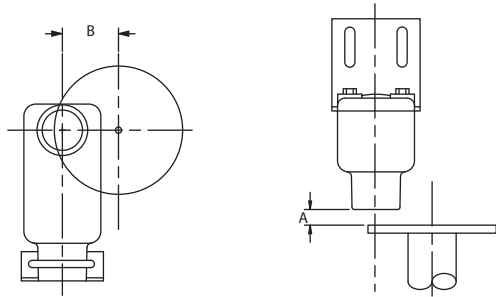

Figure 3: Explosionproof 907 Sensor with Pulser Disc

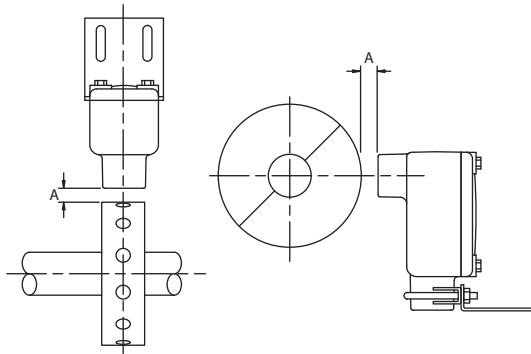

Figure 4: Explosionproof 907 Sensor with Pulser Wrap

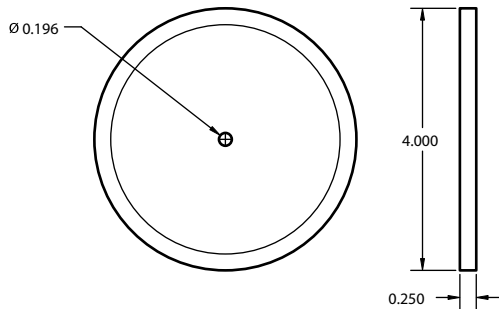

Figure 5: 255 Pulser Disc (DMS100)

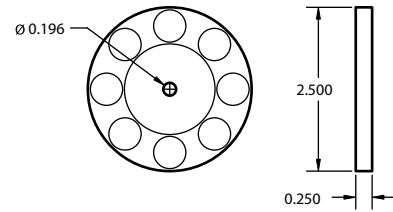

Figure 6: 256 Pulser Disc (DMS5000)

## Setup

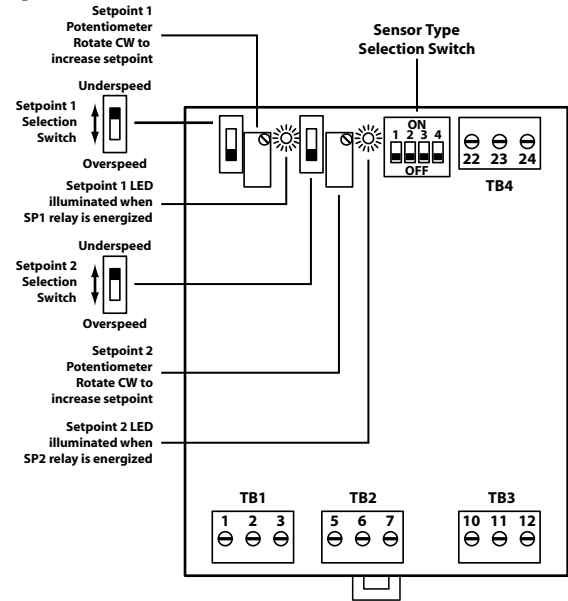

Figure 7: DMS-Series Wiring Diagram

TB1 SP1 Relay			TB2 SP2 Relay		
1	2	3	5	6	7
N.O	Comm	N.C.	N.O	Comm	N.C.

TB3 Power Input			
	10	11	12
AC	Hot	Neut	Spare
DC	+	-	Spare

TB4 Sensor Input			
Sensor Model	22	23	24
	Ground	Signal	+12 Vdc
906/907	White Shield	Black	Red
ESI Prox NPN	Blue	Black	Brown
Other ESI-Sensor NPN	Black Shield	White	Red

Sensor Type Selection Switch				
	Switch Position			
	1	2	3	4
NPN	ON	OFF	OFF	OFF
PNP	OFF	ON	OFF	OFF
Logic Level	OFF	ON	OFF	OFF
Mag Sensor	OFF	ON	ON	ON

## Calibration

1. Complete the installation of the pulser disc or wrap and the sensing head with correct gap distance.
2. Set sensor type selection switch for the sensor used. See Figure 7.
3. Determine whether the relay should de-energize when the shaft drops below the set point speed (under speed operation) or when the shaft speed goes above the set point speed (over speed operation). Use the over/under speed selection switch or switches to place the DMS in the desired mode. See Figure 7.
4. Apply power to the DMS.
5. For under speed mode, and with the shaft turning at the slowdown set point speed, turn the potentiometer (set point 1) counterclockwise until set point 1 LED is on.
6. Turn potentiometer (set point 1) clockwise until set point 1 LED is off. With this setting the speed switch will de-energize at that point when it slows down from normal operation. The green LED is illuminated when the relay is energized during normal operation.
7. For over speed mode, and with the shaft turning at it's over speed point, turn the potentiometer (set point 2) clockwise until set point 2 LED is on.
8. Turn potentiometer (set point 2) counterclockwise until set point 2 LED is off. With this setting the speed switch will de-energize at that point when it speeds up from normal operation. The green LED is illuminated when the relay is energized during normal operation.

## Sample motor shutdown circuit

Figure 8 shows a typical wiring diagram for a Motor Shutdown Control circuit with an alarm for a digital speed switch such as the DMS.

### Disclaimer

The circuit shown in Figure 8 is provided for **REFERENCE ONLY**. Electro-Sensors accepts no responsibility for the use of this circuit or any circuit used for the purpose of Motor Shutdown.

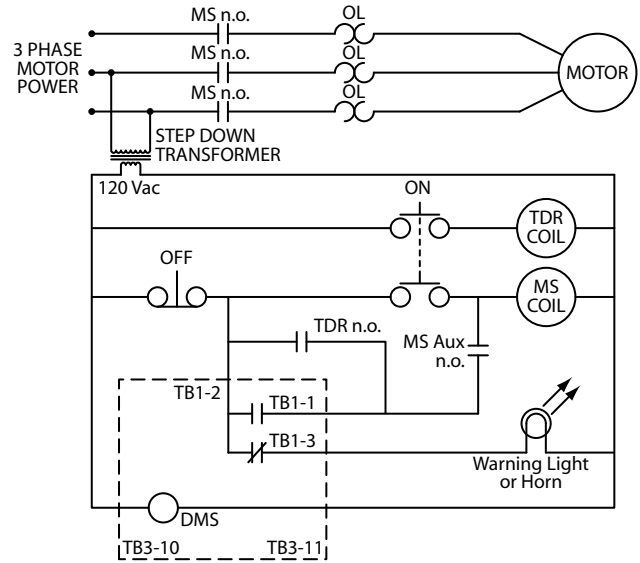

Figure 8: Sample Reference Motor Shutdown Circuit

### Wiring diagram keys:

<b>MS</b>	Motor starter ( <i>not supplied</i> )
<b>OL</b>	Overload contacts
<b>n.o.</b>	Normally open ( <i>relay is in a de-energized state</i> )
<b>TDR</b>	Time delay OFF relay is not supplied. If the shaft being monitored comes up to speed slowly, a TDR can be used so the operator will not have to hold the START button in.

### WARNING!

During a stopped condition, any slight movement of the shaft or magnetic disc could energize the control relay and start the motor—if the Motor Auxiliary Normally Open Contact (MS Aux n.o.) is not wired in series as shown Figure 8, the reference circuit. Failure to observe this warning could result in damage to the equipment or injury to persons. Always use proper Lock-Out-Tag-Out procedures.

## Enclosure Dimensions

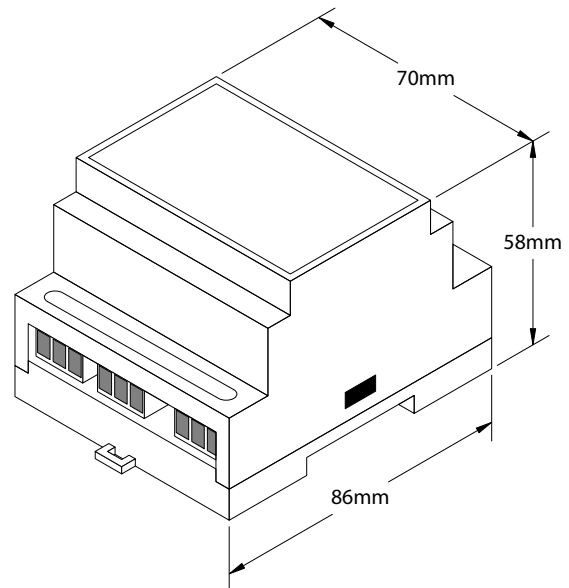

Figure 9: DMS Dimensions

Free Catalog and Application Assistance  
1.800.328.6170  
Website: [www.electro-sensors.com](http://www.electro-sensors.com)  
990-003600 Revision A

## Sensor Dimensions

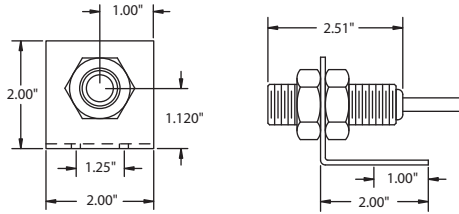

Figure 10: Standard 906 sensor dimensions

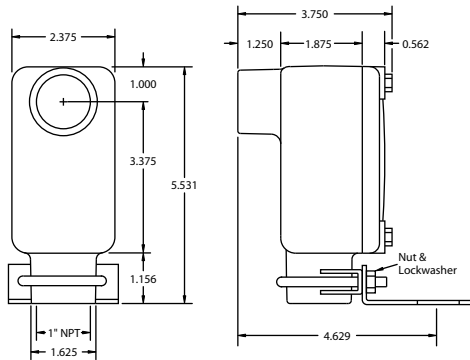

Figure 11: Explosionproof 907 Sensor dimensions

## DMS-Series speed switch specifications

Power	Parameters *
AC Models	115/230 VAC +/- 10% 50/60 Hz 1.0 VA
Recommended Fuse	0.010 A Slo-Blo
12 VDC Models	+12 VDC +/- 10% 80mA
24 VDC Models	+24 VDC +/- 10% 80mA
Recommended Fuse	0.125 A Slo-Blo
Set Point	Parameters *
2 SPDT Relays Isolated Contacts	250 VAC @ 5A Resistive +30 VDC @ 5A Resistive
Set Point Adjustment	(2) 25 turn potentiometers
Under/Over speed	Individually selectable
Set Point Hysteresis	3% +/- 1%
Set Point Accuracy	+/- 0.5%
Electrical Connections	Terminal Block
Housing & Cover	Parameters *
Base	Noryl (Plastic)
Housing	Lexan (Polycarbonate)
Mounting	35 mm DIN Rail
Sensing Head	Parameters *
Power	20 mA Maximum
Type	Switch Selectable: NPN, PNP, Mag Sensor, or Logic Level



Adjustment Range	Parameters *
DMS100	5 RPM to 100 RPM with 8 PPR input
DMS5000	100 RPM to 5000 RPM with 4 PPR input
Operating temp	0°C to +50°C

255 Pulser Disc (std.)	Parameters **
Material	Nylon 12 Std, (opt; PVC, Alum, Stainless-Steel)
Dimensions	4-inch diameter x 1/4-inch thick
Operating Temperature	-40°C to +60°C* (Nylon, PVC)
Operating Temperature	-40°C to +150°C* (Alum, SS)

256 Pulser Disc DMS5000	Parameters *
Material	PVC Std, (opt; Alum, Stainless-Steel)
Dimensions	2.5" diameter x 1/4" thick
Operating Temperature	-40°C to +60°C* (PVC)
Operating Temperature	-40°C to +150°C* (Alum, SS)

Pulser Wrap (optional)	Parameters **
Material	PVC Std. (opt; Aluminum or Stainless-Steel)
Operating Temperature	-40°C to +60°C* (PVC)
Operating Temperature	-40°C to +150°C* (Aluminum, SS)

906 Sensor (Standard)	Parameters **
Material Sensor Body	Aluminum 3/4 - 16UNF thread
Material Mount Bracket	Plate steel
Output Types	NPN open collector current sinking 20 mA max
Signal Cable	3-conductor shielded, 10 feet length std. (50 ft. or 100 ft. optional)
Operating Temperature	-40°C to + 60°C*
Air Gap	1/4 inch +/- 1/8 inch

907 Explosionproof Sensor (optional)	Parameters **
	Class I, Div 1, Group D Class II, Div 1, Groups E, F, G UL File: E249019
	
Mounting Bracket Material	Plate Steel U-Bolt Assembly
Other Specifications	Similar to 906 standard sensor

**Specifications are subject to change without notice.**

**\*For higher or lower temperature ranges, consult factory.**

**\*\* For details on Discs, Wraps and Sensors, consult factory or visit our website.**